

HELICAL



国标电机



高效率



造型美观



运行稳定

HYPONE GEAR REDUCER

小型 TKM 斜齿 - 准双曲面齿轮 减速器



KSE

温州库盛电机科技有限公司

产品目录 Product Contents

产品总概述 - Product overview 01-10

产品构造原理 - Basic structure	02
概述 - Summarize	03
型号说明 - Model Description	04
选型相关参数 - Selection related parameters	05
选型举例 - Selection example	10

减速器选型表 - Product overview 11-13

减速器组合表 - Possible geometrical combinations	11
--------------------------------------------	----

性能参数 - Performance parameter 14-28

TKM..(KW) 性能参数 - Performance parameter	14
----------------------------------------	----

外形尺寸图表 - Outline dimension sheet 29-43

外形尺寸图表 - Outline dimension sheet	29
附件尺寸图表 - Outline dimension sheet	39
安装方位图 - Installation positions diagram	40
安装 - Intallation	42

润滑油 - Lubricants 44-49

润滑油 - Lubricants	44
维护 - Maintain	45
存放/定货须知 - Storage/Notice for order	45

运转故障 - Mulfunctions 47-49

减速器运转故障 - Gear unit malfunc tions	47
减速器负载特征表 - Charge characteristic chart	48

TKM SERIES

HELICAL-HYPOID GEAR UNITS

• 斜齿-准双曲面齿轮减速器 •

UL CE IEC MV

- TKM SERIES -

- TKM28B~58B (IEC)
- TKM28B~58B (MV)
- TKM28C~58C (IEC)
- TKM28C~58C (MV)

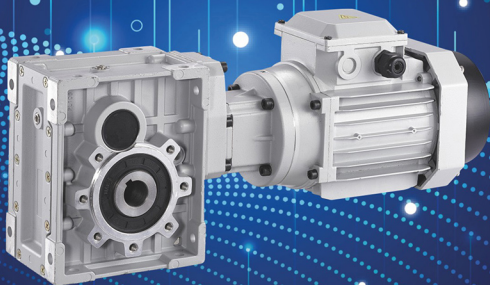

产品构造原理 BASIC STRUCTURE

1.1 产品构造原理 Basic structure

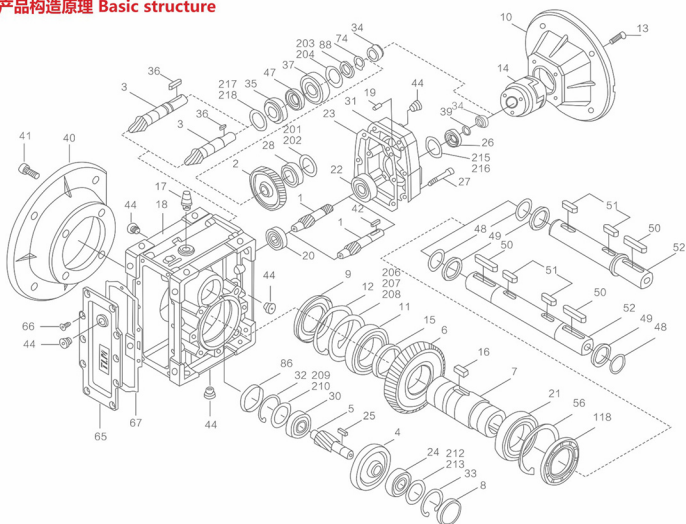

1. 主动齿轮 /Pinion	25. 键 /Key	56. 孔用挡圈 /Hole-circlip
2. 从动齿轮 /Gear	26. 油封 /Oil seal	65. 齿轮箱盖板 /Gearcase cover
3. 主动齿轮轴 /Pinion shaft	27. 内六角螺钉 /Inner hex screw	66. 内六角沉头螺钉 /Hexagon sunk screw
4. 从动齿轮 /Gear	28. 轴承 /Anti-friction bearing	67. 橡胶垫 /Rubber gasket
5. 主动齿轮轴 /Pinion shaft	30. 轴承 /Anti-friction bearing	74. 轴用挡圈 /Shaft-circlip
6. 从动齿轮 /Gear	31. 三级齿轮箱 /3 stage gearcase	86. 油封盖 /Closing cap
7. 输出轴 /Hollow shaft	32. 孔用挡圈 /Hole-circlip	88. 垫圈 /Washer
8. 油封盖 /Closing cap	33. 孔用挡圈 /Hole-circlip	118. 油封 /Oil seal
9. 油封 /Oil seal	34. 橡胶套 /Rubberboot	201. 调整垫片 /Shim ring
10. 输入法兰 /Input flange	35. 轴承 /Anti-friction bearing	202. 调整垫片 /Shim ring
11. 轴承 /Anti-friction bearing	36. 键 /Key	205. 调整垫片 /Shim ring
12. 孔用挡圈 /Hole-circlip	37. 轴承 /Anti-friction bearing	206. 调整垫片 /Shim ring
13. 内六角螺钉 /Inner hex screw	39. 轴用挡圈 /Shaft-circlip	207. 调整垫片 /Shim ring
14. 输入轴 /Input shaft	40. 输出法兰 /Output flange	208. 调整垫片 /Shim ring
15. 间隔套 /Spacer	41. 内六角螺钉 /Inner hex screw	209. 调整垫片 /Shim ring
16. 键 /Key	42. 键 /Key	210. 调整垫片 /Shim ring
17. 排气阀 /Breather valve	44. 油塞 /Oil plug	211. 调整垫片 /Shim ring
18. 齿轮箱体 /Gearcase	47. 油封 /Oil seal	212. 调整垫片 /Shim ring
19. 圆柱销 /Stifte	48. 轴用挡圈 /Shaft-circlip	213. 调整垫片 /Shim ring
20. 轴承 /Anti-friction bearing	49. 垫片 /Gasket	214. 调整垫片 /Shim ring
21. 轴承 /Anti-friction bearing	50. 键 /Key	215. 调整垫片 /Shim ring
22. 轴承 /Anti-friction bearing	51. 键 /Key	216. 调整垫片 /Shim ring
23. 密封纸垫片 /Housing gasket	52. 双向输出轴 /Double output shaft	217. 调整垫片 /Shim ring
24. 轴承 /Anti-friction bearing	53. 单向输出轴 /Single output shaft	

概述 SUMMARIZE

2.1产品特点

TKM系列斜齿-准双曲面齿轮减速器是我公司自主研发的新一代实用性产品。融合了国内外先进技术，具有以下一些主要特点：

- ✓ 采用准双曲面齿轮传动，传动比大；
- ✓ 输出扭矩大，传动效率高，节能环保；
- ✓ 质铝合金铸造，重量轻，不生锈；
- ✓ 传动平稳，噪音小，适合在恶劣环境中长期连续工作；
- ✓ 美观耐用，体积小；
- ✓ 可适应全方位安装，应用广泛，使用方便；
- ✓ TKM系列减速器安装尺寸与TNRV系列蜗轮蜗杆减速器完全兼容（TKM28与TNRV050部分尺寸不同）；
- ✓ 模块化组合，可多种形式组合，满足各种传动条件的需求。

2.2主要材料

- ✓ 外壳：铝合金(机座：28-58)；
- ✓ 齿轮：20CrMnTiH1，渗碳淬火，齿面硬度56-62 HRC，精磨后保持渗碳层厚度0.3-0.5mm；

2.3表面涂装

- 铝合金外壳
 - ✓ 先抛丸处理，再经特种防腐处理，保持银白金属感，并耐汽油，二甲苯等有机溶剂的腐蚀；
 - ✓ 磷化处理后，再喷RAL9022银灰色涂料。

2.1 Products characteristics

TKM series helical-hypoid gear units is a new-generation of product developed by our company with a compromise of advanced technology both at home and abroad, its main features areas follows:

- ✓ Driven by hypoid gear, has big ratios.
- ✓ Large in output torque, high efficiency, energy saving and environmental protection.
- ✓ Made of high-quality aluminum alloy, light in weight and nonrusting.
- ✓ Smooth in running and low in noise, can work long time in dreadful conditions.
- ✓ Good-looking in appearance, durable in service life and small in volume.
- ✓ Suitable for all round installation, wide application and easy of use.
- ✓ The mounting dimension of TKM series are compatible with TNRV series worm gear unit (A part of TNRV050 dimensions are different from TKM28).
- ✓ Modulaw and multistructure can meet the demands of various conditions.

2.2 Main materials

- ✓ Housing: die-cast aluminum alloy (framesize: 28 to 58);
- ✓ Gear wheel: 20CrMnTiH1, carburize & quencher heat treatment make the hardness of gear's surface up to 56-62HRC, retain carburization layer's thickness between 0.3 and 0.5mm after precise grinding.

2.3 Surface painting

- Aluminum alloy housing
 - ✓ Shot blasting and special antiseptic treatment on the aluminum alloy surface.
 - ✓ After phosphating, spray the paint RAL9022 in silver white.

型号说明 MODEL ILLUMINATE

3.1 减速电机/Geared motor



NO	说明	Comments
1	减速器系列代号: TKM	Code for gear units series : TKM
2	减速器规格代号: 28、38、48、58、68	Specification code of gear units 28、38、48、58、68
3	1).B: 表示2级传动 2).C: 表示3级传动	1).B : Means 2 stages 2).C : Means 3 stages
4	减速器速比	Speed ratio of reducer i
5	1) .无代号表示不带输出法兰 2) .FA, FB, FC, FD, FE (1/2) : 输出法兰代号和位置	1). No mark means without output flange 2). FA, FB, FC,FD, FE(1/2): output Flange and positionl
6	1) .无代号表示孔输出 2) .SS (1/2) : 单向输出轴和位置 3) .DS: 双向输出轴	1). No mark means hole output 2). SS(1/2): Single output shaft and position 3). DS: Double output shaft
7	1) .输入法兰规格代号 (63B5、71B5、71B14……) 2) .HS: 表示轴输入	1). Input flange code(63B5、71B5、71B14……) 2). HS: means Shaft input
8	安装方位代号	Installation position code
9	1) .无代号表示不带电机 2) .电机型号或功率、极数	1). No code indicates no motor 2). Motor model or power, number of poles
10	电机接线盒位置, 默认位置1可以不写	Motor junction box position, default position 1 can not write

订单时请说明是否带电机, 一般按不带电机供应。

When ordering, you should show whether the reducers are equipped with motors. otherwise reducers aren't supplied with motors.

示例 Example: TKM58C - 200.66 - B3 - MV71D4

选型相关参数 SELECTION RELATED PARAMETERS

4.1功率P

- ☑ $P_1 = \frac{P_2}{\eta}$ [kW]
- ☑ $P_{1n} \geq P_1 \cdot f_s$ [kW]
- ☑ P_1 输入功率
- ☑ P_2 输出功率
- ☑ P_{1n} 电机额定功率
- ☑ f_s 使用系数
- ☑ η 传动效率

TKM系列减速器的效率是根据传动级数确定，2级传动效率 η 为92%，3级传动效率 η 为90%。

4.2转速n

- ☑ n_1 减速器输入转速
- ☑ n_2 减速器输出转速

若是齿轮箱外部传动装置驱动，为了优化工作条件和提高使用寿命，建议使用1400r/min或更低转速。允许输入较高的输入转速，但在这种情况下，额定扭矩M2会下降。

4.3传动比

- ☑ $i = \frac{n_1}{n_2}$
- ☑ 传动比通常为小数，在选型表中保留两位小数。

4.4扭矩M

- ☑ $M_2 = \frac{9550 \cdot P_1 \cdot \eta}{n_2}$ [Nm]
- ☑ $M_{2n} \geq M_2 \cdot f_s$ [Nm]
- M_2 输出扭矩
- M_{2n} 选用输出扭矩
- P_1 输入功率
- η 传动效率
- f_s 使用系数

4.5使用系数 f_s

使用减速器时，应考虑一定的使用系数 f_s ，它是根据每天的运转时间和启停频率Z确定的。根据惯性加速系数确定三种负载类型，在下图中可以读取实际应用的使用系数，按下图选取的使用系数必须小于或等于从性能参数表中提供的使用系数。

4.1 Power P

- ☑ $P_1 = \frac{P_2}{\eta}$ [kW]
- ☑ $P_{1n} \geq P_1 \cdot f_s$ [kW]
- ☑ P_1 Input power
- ☑ P_2 Output power
- ☑ P_{1n} Rated power driving motor
- ☑ f_s Service factor
- ☑ η Transmission efficiency

The efficiency of TKM gear units varies with the number of gear stages, between 94 % (2-stage), 92 % (3-stage).

4.2 Rotation speed n

- ☑ n_1 Gear units input speed
- ☑ n_2 Gear units output speed

If driven by the external gearing, 1400r/min or lower rotation speed is suggested so as to optimize the working conditions and prolong the service life. Higher input rotation speed is permitted, but in this situation, the rated torque M2 will be reduced.

4.3 Transmission ratio i

- ☑ $ni = \frac{n_1}{n_2}$
- ☑ Usually transmission ratio is decimal fraction with 2 radix point tagged in selection tables.

4.4 Torque M

- ☑ $M_2 = \frac{9550 \cdot P_1 \cdot \eta}{n_2}$ [Nm]
- ☑ $M_{2n} \geq M_2 \cdot f_s$ [Nm]
- M_2 Output torque
- M_{2n} Selected output torque
- P_1 Input power
- η Transmission efficiency
- f_s Service factor

4.5 Service factor f_s

The effect of the driven machine on the gear unit is taken into account to a sufficient level of accuracy using the service factor f_s . The service factor is determined according to the daily operating time and the starting frequency Z. Three load classifications are considered depending on the mass acceleration factor. You can read off the service factor applicable to your application in following Figure.

选型相关参数 SELECTION RELATED PARAMETERS

The service factor selected using this diagram must be less than or equal to the service factor as given in the performance parameter table.

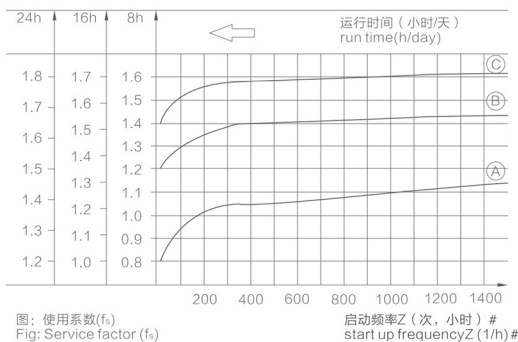

启动频率Z: 周期包括所有启动、制动的次数以及变速电机高低速变化时的次数。

starting frequency Z: The cycles include all starting and braking procedures as well as change overs from low to high speed.

4.5.1 负载类型

- ☑ A 均匀冲击负载, 允许惯性加速系数 $f_a \leq 0.2$
- ☑ B 中等冲击负载, 允许惯性加速系数 $f_a \leq 3$
- ☑ C 重冲击负载, 允许惯性加速系数 $f_a \leq 10$

负载类型:

轻负载的螺杆输送, 风扇, 装配线, 输送带, 小型搅拌机, 电梯, 清洗机器, 过滤器, 控制驱动。

卷扬机, 木工机器进料器, 货物起重机, 平衡器, 纹螺纹机器, 中型搅拌机, 重型输送带, 绞盘, 滑动闸门, 刮料机, 包装机械, 混凝土搅拌机, 行车驱动装置, 铣床, 齿轮泵。

大型搅拌机, 剪床, 压机, 离心机, 旋转支撑装置, 重型绞盘和起重机械, 磨床, 石材打磨机, 翻斗机, 钻床, 冲床, 凸轴压机, 摺床, 机床转盘, 翻桶装置, 振荡装置, 破碎机。

4.5.2 惯性加速系数

- ☑ 惯性加速系数计算如下:

$$f_a = \frac{Jc}{Jm}$$

4.5.1 load classifications

- ☑ A Uniform, permitted mass acceleration factor $f_a \leq 0.2$
- ☑ B Moderate shock load, permitted mass acceleration factor $f_a \leq 3$
- ☑ C Heavy shockload, permitted mass acceleration factor $f_a \leq 10$

oad classifications:

Screw feeders for light materials, fans, assembly lines, conveyor belts for light materials, small mixers, lifts, cleaning machines, filters, control machines.

Winding devices, woodworking machine feeders, goods lifts, balancers, threading machines, medium mixers, conveyor belts for heavy materials, winches, sliding doors, fertilizer scrapers, packing machines, concrete mixers, crane mechanisms, milling cutters, folding machines, gear pumps.

Mixers for heavy materials, shears, presses, centrifuges, rotating supports, winches and lifts for heavy materials, grinding lathes, stone mills, bucket elevators, drilling machines, hammer mills, cam presses, folding machines, turntables, tumbling barrels, vibrators, shredders.

4.5.2 Mass acceleration factor

- ☑ the mass acceleration factor is calculated as follows:

$$f_a = \frac{Jc}{Jm}$$

选型相关参数 SELECTION RELATED PARAMETERS

- ☑ f_a 惯性加速系数
 - ☑ J_e 所有外部传动惯量(kgm²)
 - ☑ J_m 驱动电机的传动惯量(kgm²)
 - ☑ f_a Mass acceleration factor
 - ☑ J_e All external mass moments of inertia (kgm²)
 - ☑ J_m Mass moment of inertia on the motor end (kgm²)
- 如果惯性加速系数 $f_a > 10$, 请与我们技术部联系。
If mass acceleration factors $f_a > 10$, please call our Technical Service.

为了保持减速器的使用寿命, 从产品样本中的性能参数表所选择的使用系数 f_s 应等于或略高于计算出的使用系数 f_s 。
举例:

惯性加速系数2.5(负载类型B), 运行时间14小时/天, (按16小时/天查图) 和每小时200次起停, 查图得使用系数 $f_s = 1.48$ 。根据性能参数表所选择的使用系数 $f_s \geq 1.48$ 。

To keep the service-life of gear units, the use factor f_s selected from the catalogue must be equal or slightly higher than the calculated use factor f_s .

Example:
Mass acceleration factor 2.5 (load classification B), 14 hours/day operating time (read off at 16h/d) and 200 cycles/hour result in a service factor $f_s = 1.48$ choose the service factor $f_s = 1.48$ according to the parameter sheet.

4.6 径向载荷和轴向载荷

在确定影响径向载荷时, 必须考虑安装在轴端上的传动件类型。不同类型的传动件的传动附加系数 f_z 列表如下:

4.6 Overhung loads and axial forces

When determining the resulting radial loads, the type of transmission elements, mounted on the shaft end must be considered. Various transmission elements are corresponding with following transmission element factors f_z :

传动件 Transmission element	传动附加系数 f_z Transmission element factor F_z	注释 Comments
齿轮 Gears	1.15	< 17齿teeth
链轮 Chain sprockets	1.25	< 20齿teeth
	1.40	< 13齿teeth
V带轮 Narrow V-belt pulleys	1.75	有预紧力作用Influence of the tensile force
平带轮 Flat belt pulleys	2.50	有预紧力作用Influence of the tensile force
齿带轮 Toothed belt pulleys	2.50	有预紧力作用Influence of the tensile force

- ☑ 作用在电机和齿轮轴上的径向载荷按如下公式计算:

$$F_r = \frac{M \cdot 2000 \cdot f_z}{d_0} \quad [N]$$

F_r 作用在轴上的载荷[N]

M 作用在轴上的扭矩[Nm]

d_0 安装在轴上传动件的平均直径[mm]

f_z 传动附加系数

- ☑ The overhung loads exerted on the motor or gear shaft is then calculated as follows:

$$F_r = \frac{M \cdot 2000 \cdot f_z}{d_0} \quad [N]$$

F_r Resulting radial load [N]

M Torque on the shaft [Nm]

d_0 Mean diameter of the mounted transmission element in [mm]

f_z Transmission element factor

许用径向载荷是根据轴承额定使用寿命L_{10h}来估算的(根据ISO281)。对于特殊的运行条件, 许用径向载荷是根据修正使用寿命L_{na}来确定。

The basis for determining the permitted radial loads is the computation of the rated service life L_{10h} of the bearings (according to ISO281). For special operating conditions, the permitted radial loads can be determined with regard to the modified service life L_{na}.

选型相关参数 SELECTION RELATED PARAMETERS

当作用点偏离出轴中点时，许用径向载荷须按以下公式来计算，取在x点的许可数值 F_{XL} （根据轴承的使用寿命）

根据轴承的使用寿命公式：

$$F_{XL} = F_r(1,2) \cdot \frac{a}{b+x} \text{ [N]}$$

F_{r1}, F_{r2} =性能参数表中的许用径向载荷($x=L/2$) [N]

x =从轴肩到受力点的距离【mm】

a, b, =减速器径向转化常量【mm】

The permitted radial loads given in the selection tables must be calculated using the following formula in the event of force application not in the center of the shaft end. The smaller of the two values F_{XL} (according to bearing service life) F_{XL} according to bearing service life :

$$F_{XL} = F_r(1,2) \cdot \frac{a}{b+x} \text{ [N]}$$

F_{r1}, F_{r2} = Permitted overhung load ($x = L/2$) for foot-mounted gear units according to the selection tables in [N]

x = Distance from the shaft shoulder to the force application point in [mm]

a, b = Gear unit constant for overhung load conversion [mm]

输出轴向载荷

$$F_{a2} = F_{r2} \times 0.2$$

F_{a2} = 输出轴向载荷
Output axial loads

Output shafts radial loads

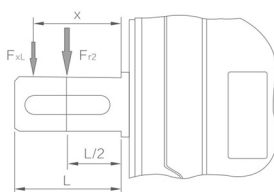

TKM减速器径向转化常量

Gear unit constants for overhung load conversion

	TKM28B	TKM28C	TKM38B	TKM38C	TKM48B	TKM48C	TKM58B	TKM58C
a	104	104	118	118	131	131	159	159
b	78	78	93	93	101	101	119	119

输入轴向载荷

F_{a1} = 输入轴向载荷
Input axial loads

Input shafts radial loads

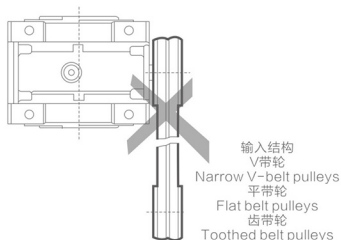
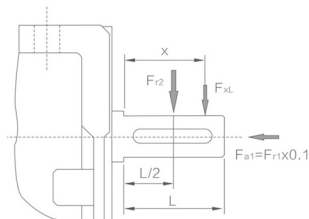

输入结构
V带轮
Narrow V-belt pulleys
平带轮
Flat belt pulleys
齿带轮
Toothed belt pulleys

选型相关参数 SELECTION RELATED PARAMETERS

右示图的输入不被允许使用（包括三级输入）。

It is forbidden to use the input on the right chart (including 3 stage input).



TKM减速器径向转化常量/Gear unit constants for overhung load conversion:

	TKM28B	TKM28C	TKM38B	TKM38C	TKM48B	TKM48C	TKM58B	TKM58C
a	51.5	56	58	56	73	70	81	70
b	40	44.5	43	44.5	53	55	61	55

4.7 选型表注释

-  表示电机与减速器的组合是可行的
表示电机与减速器的组合是不可行的
- * 表示速比可除尽
- P_{1n} 电机额定功率【kW】；
- n₂ 输出转速【r/min】；
- M_{2n} 输出扭矩【Nm】；
- M_{2max} 最大允许输出扭矩【Nm】；
- F_{r2} 输出轴径向载荷【N】；
- i 减速器公称传动比；
- i_a 减速器实际传动比；
- f_s 使用系数；
-  减速器型号；
-  电机型号；
- page 外形尺寸表页码；

4.7 Selection table annotation

-  Combination with the motor in the header row is possible
Combination with the motor in the header row is not possible
- * Finite gear unit reduction ratio;
- P_{1n} Rated power driving motor [kW];
- n₂ Output speed [r/min];
- M_{2n} Output torque [Nm];
- M_{2max} Max. permissible output torque [Nm];
- F_{r2} Permissible overhung load output side [N];
- i Gear unit nominal ratio;
- i_a Gear unit actual ratio;
- f_s Service factor;
-  Gear unit type;
-  Motor type;
- page Dimension sheet page no;

选型举例 Selection example

5 选型举例

5.1 减速电机

例：被驱动设备所需功率0.25kW工作8小时/天，中等冲击，启动频率100次/小时，输出转速 $n_2=35r/min$ ，减速机要求B3安装，则：

查P7使用系数图表即可选使用系数 $f_s=1.3$

$$i = \frac{n_1}{n_2} = \frac{1400}{35} = 40$$

$$P_{1n} \geq P_1 \cdot f_s = \frac{P_2}{\eta} \cdot f_s = \frac{0.25}{0.94} \cdot 1.3 = 0.345[\text{kW}]$$

查TKM系列性能参数表可确定减速机型号为：
TKM28B-40.09-71B5-7124-B3

5.2 减速器

例：被驱动设备所需扭矩为200Nm，工作8小时/天，均匀冲击负载，启动频率400次/小时，减速机要求FA1法兰安装，减速器要求输入转速900r/min，输出转速 $n_2=6r/min$ ，查性能参数表可知，只选能三级传动形式。

查P7使用系数图表即可选使用系数 $f_s=1.05$

$$i = \frac{n_1}{n_2} = \frac{900}{6} = 150$$

$$M_{2n} \geq M_2 \cdot f_s = 200 \times 1.05 = 210[\text{Nm}]$$

$$P_{1n} \geq P_1 \cdot f_s = \frac{M_2 \cdot n_1}{9550 \cdot \eta \cdot i} \cdot f_s = \frac{210 \times 900}{9550 \times 0.92 \times 150} \cdot 1.05 = 0.151[\text{kW}]$$

查TKM系列性能参数表可确定减速型号为：
TKM48C-151.20-FA1

5 SELECTION EXAMPLE

5.1 Gear motor

Example: Required power 0.25kW on driven machine, work for 8h/day, moderate shock load, start up frequency 100(1/h), $n_2=35r/min$, B3 mounted, So: Check the service factor table at page 7, choose $f_s=1.3$

Choose type:
TKM28B-40.09-71B5-7124-B3

5.2 Gear units

Example: Required torque 200Nm on driven machine, work 8 h/day, uniform load, start up frequency 400(1/h), FA1 mounted, $n_1=900 r/min$, $n_2=2.5 r/min$, so the only selection is 3 stage after checked the table: Check the service factor to ble at page 7 ,choose $f_s=1.05$

choose type:
TKM48C-151.20-FA1

減速器組合表 POSSIBLE GEOMETRICAL COMBINATIONS

■ **TKM28..** $n_1 = 1400\text{r/min}$

130Nm

減速器型号 Gear units		I 公称 Nominal	I 实际 Actual	n_2 [r/min]	M2max [Nm]	F_{r2} [N]	63B5	71B5 71B14	80B5 80B14	90B5 90B14
3級 / 3 Stage										
TKM28C		300	291.79	4.8	130	4100				
TKM28C		265	262.61	5.3	130	4100				
TKM28C		250	244.29	5.7	130	4100				
TKM28C		220	219.86	6.4	130	4100				
TKM28C		200	200.44	7.0	130	4100				
TKM28C		180	180.40	7.8	130	4100				
TKM28C		150	146.67	9.5	130	4000				
TKM28C		135	132.00	10.6	130	3890				
TKM28C		125	120.34	11.6	130	3770				
TKM28C		110	108.31	12.9	130	3640				
TKM28C		100	101.04	13.9	100	3560				
TKM28C		90	90.93	15.4	100	3440				
TKM28C		75	74.62	18.8	80	3220				
TKM28C		70	67.16	21.0	80	3110				
2級 / 2 Stage										
TKM28B		60	58.36	24	130	2960				
TKM28B		50	48.86	29	130	2790				
TKM28B		40	40.09	35	130	2610				
TKM28B		30	29.33	48	130	2350				
TKM28B		25	24.07	58	130	2200				
TKM28B		20	20.21	69	100	2080				
TKM28B		15	14.92	94	80	1880				
TKM28B		12.5	12.47	112	130	1770				
TKM28B		10	10.47	134	100	1670				
TKM28B		7.5	7.73	181	80	1510				

■ **TKM38..** $n_1 = 1400\text{r/min}$

200Nm

減速器型号 Gear units		I 公称 Nominal	I 实际 Actual	n_2 [r/min]	M2max [Nm]	F_{r2} [N]	63B5	71B5 71B14	80B5 80B14	90B5 90B14
3級 / 3 Stage										
TKM38C	TKB38C	300	302.50	10.3	10.3	4800				
TKM38C	TKB38C	265	272.25	11.5	11.5	4800				
TKM38C	TKB38C	250	243.57	4.6	4.6	4800				
TKM38C	TKB38C	220	219.21	5.1	5.1	4800				
TKM38C	TKB38C	200	196.43	5.7	5.7	4800				
TKM38C	TKB38C	180	176.79	6.4	6.4	4800				
TKM38C	TKB38C	150	151.56	7.1	7.1	4650				
TKM38C	TKB38C	135	136.40	7.9	7.9	4490				
TKM38C	TKB38C	125	122.22	9.2	9.2	4330				

减速器组合表 POSSIBLE GEOMETRICAL COMBINATIONS
■ TKM38.. $n_1 = 1400r/min$
200Nm

减速器型号 Gear units		I 公称 Nominal	I 实际 Actual	n_2 [r/min]	M2max [Nm]	F_r [N]	63B5	71B5 71B14	80B5 80B14	90B5 90B14
3级 / 3 Stage										
TKM38C	TKB38C	110	110.00	12.7	12.7	4180				
TKM38C	TKB38C	100	101.27	13.8	13.8	4070				
TKM38C	TKB38C	90	91.14	15.4	15.4	3930				
TKM38C	TKB38C	75	73.33	19.1	19.1	3650				
TKM38C	TKB38C	70	66.00	21	21	3530				
2级 / 2 Stage										
TKM38B	TKB38B	60	60.50	23	200	3430				
TKM38B	TKB38B	50	48.71	29	200	3190				
TKM38B	TKB38B	40	39.29	36	180	2970				
TKM38B	TKB38B	30	30.31	46	200	2720				
TKM38B	TKB38B	25	24.44	57	180	2530				
TKM38B	TKB38B	20	20.25	69	150	2380				
TKM38B	TKB38B	15	14.67	95	110	2130				
TKM38B	TKB38B	12.5	12.67	110	180	2030				
TKM38B	TKB38B	10	10.50	133	150	1910				
TKM38B	TKB38B	7.5	7.60	184	110	1710				

■ TKM48.. $n_1 = 1400r/min$
350Nm

减速器型号 Gear units		I 公称 Nominal	I 实际 Actual	n_2 [r/min]	M2max [Nm]	F_r [N]	63B5	71B5	80B5 80B14	90B5 90B14	100B5 100B14	112B5 112B14
3级 / 3 Stage												
TKM48C	TKB48C	300	297.21	4.7	350	6500						
TKM48C	TKB48C	265	267.49	5.2	350	6500						
TKM48C	TKB48C	250	240.89	5.8	350	6500						
TKM48C	TKB48C	220	216.80	6.5	350	6500						
TKM48C	TKB48C	200	200.66	7.0	300	6500						
TKM48C	TKB48C	180	180.60	7.8	300	6500						
TKM48C	TKB48C	150	151.20	9.3	350	6360						
TKM48C	TKB48C	135	136.08	10.3	350	6140						
TKM48C	TKB48C	125	125.95	11.1	300	5980						
TKM48C	TKB48C	110	113.36	12.4	300	5770						
TKM48C	TKB48C	100	99.22	14.1	240	5520						
TKM48C	TKB48C	90	89.29	15.7	240	5330						
TKM48C	TKB48C	75	75.45	18.6	200	5040						
TKM48C	TKB48C	70	67.90	21	200	4870						
2级 / 2Stage												
TKM48B	TKB48B	60	59.44	24	350	4660						
TKM48B	TKB48B	50	48.18	29	350	4340						

减速器组合表 POSSIBLE GEOMETRICAL COMBINATIONS

■ **TKM48..** $n_1 = 1400r/min$

350Nm



减速器型号 Gear units		公称 Nominal	实际 Actual	n_2 [r/min]	M2max [Nm]	F_{r2} [N]	63B5	71B5	80B5 80B14	90B5 90B14	100B5 100B14	112B5 112B14
2级 / 2Stage												
TKM48B	TKB48B	40	40.13	35	300	4080						
TKM48B	TKB48B	30	30.24	46	350	3720						
TKM48B	TKB48B	25	25.19	56	300	3500						
TKM48B	TKB48B	20	19.84	71	240	3230						
TKM48B	TKB48B	15	15.09	93	200	2950						
TKM48B	TKB48B	12.5	12.49	112	300	2770						
TKM48B	TKB48B	10	9.84	142	240	2550						
TKM48B	TKB48B	7.5	7.48	187	200	2330						

■ **TKM58..** $n_1 = 1400r/min$



500Nm

减速器型号 Gear units		公称 Nominal	实际 Actual	n_2 [r/min]	M2max [Nm]	F_{r2} [N]	63B5	71B5	80B5 80B14	90B5 90B14	100B5 100B14	112B5 112B14
3级 / 3 Stage												
TKM58C	TKB58C	300	295.18	4.7	500	8300						
TKM58C	TKB58C	265	265.66	5.3	500	8300						
TKM58C	TKB58C	250	240.89	5.8	500	8300						
TKM58C	TKB58C	220	216.80	6.5	500	8300						
TKM58C	TKB58C	200	200.66	7.0	480	8300						
TKM58C	TKB58C	180	180.60	7.8	480	8300						
TKM58C	TKB58C	150	151.20	9.3	500	8050						
TKM58C	TKB58C	135	136.08	10.3	500	7780						
TKM58C	TKB58C	125	125.95	11.1	480	7580						
TKM58C	TKB58C	110	113.36	12.4	480	7320						
TKM58C	TKB58C	100	99.22	14.1	380	7000						
TKM58C	TKB58C	90	89.29	15.7	380	6760						
TKM58C	TKB58C	75	75.45	18.6	300	6390						
TKM58C	TKB58C	70	67.90	21	300	6170						
2级 / 2Stage												
TKM58B	TKB58B	60	59.04	24	500	5890						
TKM58B	TKB58B	50	48.18	29	500	5500						
TKM58B	TKB58B	40	40.13	35	480	5170						
TKM58B	TKB58B	30	30.24	46	500	4710						
TKM58B	TKB58B	25	25.19	56	480	4430						
TKM58B	TKB58B	20	19.84	71	380	4090						
TKM58B	TKB58B	15	15.09	93	300	3730						
TKM58B	TKB58B	12.5	12.49	112	480	3510						
TKM58B	TKB58B	10	9.84	142	380	3240						
TKM58B	TKB58B	7.5	7.48	187	300	2950						



TKM..性能参数 PERFORMANCE PARAMETER

P _{in} [kW]	n _i [r/min]	M _{in} [Nm]	I		F _z [N]	f _s			Page	
			公称 Nominal	实际 Actual						
0.12	5.7	184	250	244.29	4100	0.7	TKM28C	63B5	6314	37
	7.0	151	200	200.44	4100	0.9				
	9.5	110	150	146.67	4000	1.2				
	11.6	91	125	120.34	3770	1.4				
	13.9	76	100	101.04	3560	1.3				
	18.8	56	75	74.62	3220	1.4				
	22.5	47	60	62.36	3030	2.8				
	26.7	39	50	52.36	2860	2.5	TKM28B	63B5	6314	36
	24.0	45	60	58.36	2960	2.9				
	28.7	38	50	48.86	2790	3.5				
	35	31	40	40.09	2610	4.2				
	48	23	30	29.33	2350	5.8				
	58	18.5	25	24.07	2200	7.0				
	69	15.6	20	20.21	2080	6.4	TKM38C	63B5	6314	39
	94	11.5	15	14.92	1880	7.0				
	112	9.6	12.5	12.47	1770	13.5				
	134	8.1	10	10.47	1670	12.4				
	181	5.9	7.5	7.73	1510	13.5				
4.6	228	300	302.50	4800	0.9	TKM38B				
5.7	183	250	243.57	4800	1.1					
7.1	148	200	196.43	4800	1.2					
9.2	114	150	151.56	4650	1.8					
11.5	92	125	122.22	4330	2.0					
13.8	76	100	101.27	4070	2.0					
19.1	55	75	73.33	3650	2.0					
22.1	48	60	63.33	3480	3.8					
26.7	40	50	52.48	3270	3.8					
23.1	47	60	60.50	3430	4.3					
28.7	37	50	48.71	3190	4.3					
36	30	40	39.29	2970	6.0					
46	23	30	30.31	2720	8.6	TKM48C	63B5	6314	41	
4.7	224	300	297.21	6500	1.6					
5.8	181	250	240.89	6500	1.9					
7.0	151	200	200.66	6500	2.0					
9.3	114	150	151.20	6500	3.1					
11.1	95	125	125.95	5980	3.2					
14.1	75	100	99.22	5520	3.2					
18.6	57	75	75.45	5040	3.5	TKM58C	63B5	6314	43	
4.7	222	300	295.18	8300	2.2					
5.8	181	250	240.89	8300	2.8					
7.0	151	200	200.66	8300	3.2					
9.3	114	150	151.20	8050	4.4	0.18	TKM28C	63B5	6312	37
9.6	165	300	291.79	4000	0.8					
11.5	138	250	244.29	3790	0.9					
14.0	113	200	200.44	3550	1.1					
19.1	83	150	146.67	3200	1.6					
23.3	68	125	120.34	2990	1.9					
27.7	57	100	101.04	2820	1.8					
38	42	75	74.62	2550	1.9		TKM28B	63B5	6312	36
45	35	60	62.36	2400	3.7					
53	30	50	52.36	2270	3.4					
48	34	60	58.36	2350	3.9					
57	28	50	48.86	2220	4.6					
70	23	40	40.09	2070	5.6					
95	16.9	30	29.33	1870	7.7		TKM28B	63B5	6312	36
116	13.9	25	24.07	1750	9.4					
11.6	136	125	120.34	3770	1.0					
13.9	114	100	101.04	3560	0.9					
18.8	84	75	74.62	3220	0.9					
22.5	70	60	62.36	3030	1.8					
26.7	59	50	52.36	2860	1.7					



TKM..性能参数 PERFORMANCE PARAMETER

P _e [kW]	n _i [r/min]	M _{in} [Nm]	I		F _r [N]	fs			Page	
			公称 Nominal	实际 Actual						
0.18	24.0	67	60	58.36	2960	1.9	TKM28B	63B5	6322	36
	28.7	56	50	48.86	2790	2.3				
	35	46	40	40.09	2610	2.8				
	48	34	30	29.33	2350	3.8				
	58	28	25	24.07	2200	4.7				
	69	23	20	20.21	2080	4.3				
	94	17.2	15	14.92	1880	4.6				
	112	14.4	12.5	12.47	1770	9.0				
	134	12.1	10	10.47	1670	8.3				
	181	8.9	7.5	7.73	1510	9.0				
	14.4	110	60	62.36	3510	1.2				
	17.2	92	50	52.36	3310	1.1				
	15.4	105	60	58.36	3430	1.2				
	18.4	88	50	48.86	3240	1.5				
	22.4	72	40	40.09	3030	1.8				
	31	53	30	29.33	2730	2.5				
	37	43	25	24.07	2550	3.0				
	45	36	20	20.21	2410	2.8				
60	27	15	14.22	2180	3.0					
72	22	12.5	12.47	2050	5.8					
86	18.8	10	10.47	1930	5.3					
116	13.9	7.5	7.73	1750	5.8					
9.3	171	300	302.50	4650	1.2					
11.5	138	250	243.57	4330	1.5					
14.3	111	200	196.43	4030	1.6					
18.5	86	150	151.56	3690	2.3					
22.9	69	125	122.22	3440	2.6					
27.6	57	100	101.27	3230	2.6					
38	41	75	73.33	2900	2.7					
44	36	60	63.33	2760	5.0					
53	30	50	52.48	2590	5.1					
7.1	222	200	196.43	4800	0.8					
9.2	171	150	151.56	4650	1.2					
11.5	138	125	122.22	4330	1.3					
13.8	114	100	101.27	4070	1.3					
19.1	83	75	73.33	3650	1.3					
22.1	72	60	63.33	3480	2.5					
26.7	59	50	52.48	3270	2.5					
23.1	70	60	60.50	3430	2.9					
28.7	56	50	48.71	3190	3.6					
36	45	40	39.29	2970	4.0					
12.3	129	75	73.33	4230	0.9					
14.2	111	60	63.33	4030	1.6					
17.1	92	50	52.48	3790	1.6					
14.9	109	60	60.50	3970	1.8					
18.5	87	50	48.71	3690	2.3					
22.9	71	40	39.29	3440	2.6					
29.7	54	30	30.31	3150	3.7					
37	44	25	24.44	2930	4.1					
44	36	20	20.25	2760	4.1					
61	26	15	14.67	2470	4.2					
9.4	168	300	297.21	6320	2.1					
11.6	136	250	240.89	5890	2.6					
14.0	113	200	200.66	5540	2.6					
18.5	85	150	151.20	5040	4.1					
4.7	336	300	297.21	6500	1.0					
5.8	272	250	240.89	6500	1.3					
7.0	227	200	200.66	6500	1.3					
9.3	171	150	151.20	6500	2.0					
11.1	142	125	125.95	5980	2.1					
14.1	112	100	99.22	5520	2.1					
18.6	85	75	75.45	5040	2.3					
15.1	107	60	59.44	5390	3.3					
18.7	87	50	48.18	5030	4.0					
							TKM48B	71B5	7116	40

TKM..性能参数 PERFORMANCE PARAMETER

P _s [kW]	n _i [r/min]	M _{ts} [Nm]	I 公称 Nominal	I 实际 Actual	F _z [N]	fs			Page						
										← →					
0.18	4.5	353	200	200.66	6500	0.9	TKM48C	71B5	7116	41					
	6.0	266	150	151.20	6500	1.3									
	7.1	221	125	125.95	6500	1.4									
	9.1	174	100	99.22	6400	1.4									
	11.9	133	75	75.45	5840	1.5									
	14.4	110	60	62.43	5480	2.7									
	18.3	86	50	49.18	5060	2.8	TKM58C	63B5	6312	43					
	9.5	167	300	295.18	7990	3.0									
	11.6	136	250	240.89	7470	3.7									
	4.7	333	300	295.18	8300	1.5									
	5.8	272	250	240.89	8300	1.8									
	7.0	227	200	200.66	8300	2.1									
	TKM58C	9.3	171	150	151.20	8050	2.9	TKM58C	63B5	6324	43				
		11.1	142	125	125.95	7580	3.4								
		14.1	112	100	99.22	7000	3.4								
		18.6	85	75	75.45	6390	3.5								
		3.0	519	300	295.18	8300	1.0					TKM58C	71B5	7116	45
		3.7	423	250	240.89	8300	1.2								
		4.5	353	200	200.66	8300	1.4								
		6.0	266	150	151.20	8300	1.9								
		7.1	221	125	125.95	8300	2.2								
		9.1	174	100	99.22	8110	2.2								
		11.9	133	75	75.45	7400	2.3								
		14.4	110	60	62.43	6950	4.4								
18.3	86	50	49.18	6420	4.4										
0.25	19.1	115	150	146.67	3200	1.1	TKM28C	63B5	6322	37					
	23.3	94	125	120.34	2990	1.4									
	27.7	79	100	101.04	2820	1.3									
	38	59	75	74.62	2550	1.4									
	45	49	60	62.36	2400	2.7									
	53	41	50	52.36	2270	2.4					TKM28B	63B5	6322	36	
	48	47	60	58.36	2350	2.8									
	57	39	50	48.86	2220	3.3									
	70	32	40	40.09	2070	4.0									
	22.5	98	60	62.36	3030	1.3	TKM28C	71B5/B14	7114	37					
	26.7	82	50	52.36	2860	1.2									
	24.0	94	60	58.36	2960	1.4									
	28.7	78	50	48.86	2790	1.7									
	35	64	40	40.09	2610	2.0									
	48	47	30	29.33	2350	2.8					TKM28B	71B5/B14	7114	36	
	58	39	25	24.07	2200	3.4									
	69	32	20	20.21	2080	3.1									
	94	24	15	14.92	1880	3.3									
	15.4	146	60	58.36	3430	0.9	TKM28B	71B5/B14	7126	36					
	18.4	122	50	48.86	3240	1.1									
	22.4	100	40	40.09	3030	1.3									
	31	73	30	29.33	2730	1.8									
	37	60	25	24.07	2550	2.2									
	45	50	20	20.21	2410	2.0									
	60	37	15	14.92	2180	2.2									
	72	31	12.5	12.47	2050	4.2									
	86	26	10	10.47	1930	3.8									
	116	19.3	7.5	7.73	1750	4.2									
	11.5	191	250	243.57	4330	1.0					TKM38C	71B5/B14	6322	39	
	14.3	154	200	196.43	4030	1.2									
	18.5	119	150	151.56	3690	1.7									
	22.9	96	125	122.22	3440	1.9									
	27.6	79	100	101.27	3230	1.9									
	38	58	75	73.33	2900	1.9									
	44	50	60	63.33	2760	3.6									
	53	41	50	52.48	2590	3.6									
	11.5	192	125	122.22	4330	0.9	TKM38C	71B5/B14	7114	38					
	13.8	159	100	101.27	4070	0.9									
	19.1	115	75	73.33	3650	1.0									
	22.1	99	60	63.33	3480	1.8									
	26.7	82	50	52.48	3270	1.8									



TKM..性能参数 PERFORMANCE PARAMETER

P _{in} [kW]	n _i [r/min]	M _{in} [Nm]	I		F _{in} [N]	fs			Page				
			公称 Nominal	实际 Actual									
0.25	23.1	97	60	60.50	3430	2.1	TKM38B	71B5/B14	7114	38			
	28.7	78	50	48.71	3190	2.6							
	36	63	40	39.29	2970	2.9							
	46	49	30	30.31	2720	4.1							
	14.2	155	60	63.33	4030	1.2							
	17.1	128	50	52.48	3790	1.2	TKM38C	71B5/B14	7126	39			
	14.9	151	60	60.50	3970	1.3							
	18.5	121	50	48.71	3690	1.6	TKM38B	71B5/B14	7126	38			
	22.9	98	40	39.29	3440	1.8							
	29.7	76	30	30.31	3150	2.6							
37	61	25	24.44	2930	3.0								
44	50	20	20.25	2760	3.0								
61	37	15	14.67	2470	3.0								
9.4	233	300	297.21	6320	1.5	TKM48C					63B5	6322	41
11.6	189	250	240.89	5890	1.9								
14.0	157	200	200.66	5540	1.9								
18.5	119	150	151.20	5040	3.0								
22.2	99	125	125.95	4750	3.0								
28.2	78	100	99.22	4380	3.1								
37	59	75	75.45	4000	3.4								
5.8	378	250	240.89	6500	0.9		TKM48C	71B5	7114	41			
7.0	315	200	200.66	6500	1.0								
9.3	237	150	151.20	6500	1.5								
11.1	198	125	125.95	5980	1.5								
14.1	156	100	99.22	5520	1.5								
18.6	118	75	75.45	5040	1.7								
22.4	98	60	62.43	4730	3.1								
28.5	77	50	49.18	4370	3.1								
6.0	369	150	151.20	6500	0.9	TKM48C					71B5	7126	41
7.1	307	125	125.95	6500	1.0								
9.1	242	100	99.22	6400	1.0								
11.9	184	75	75.45	5840	1.1								
14.4	152	60	62.43	5480	2.0								
18.3	120	50	49.18	5060	2.0								
15.1	148	60	59.44	5390	2.4		TKM48B	71B5	7126	40			
18.7	120	50	48.18	5030	2.9								
22.4	100	40	40.13	4730	3.0								
9.5	232	300	295.18	7990	2.2	TKM58C	71B5	6322	43				
11.6	189	250	240.89	7470	2.6								
14.0	157	200	200.66	7030	3.0								
18.5	119	150	151.20	6390	4.2								
4.7	463	300	295.18	8300	1.1					TKM58C	71B5	7114	43
5.8	378	250	240.89	8300	1.3								
7.0	315	200	200.66	8300	1.5								
9.3	237	150	151.20	8050	2.1								
11.1	198	125	125.95	7580	2.4								
14.1	156	100	99.22	7000	2.4								
18.6	118	75	75.45	6390	2.5								
22.4	98	60	62.43	6000	4.9								
28.5	77	50	49.18	5540	4.9								
3.7	588	250	240.89	8300	0.9	TKM58C	71B5	7126	43				
4.5	490	200	200.66	8300	1.0								
6.0	369	150	151.20	8300	1.4								
7.1	307	125	125.95	8300	1.6								
9.1	242	100	99.22	8110	1.6								
11.9	184	75	75.45	7400	1.6								
14.4	152	60	62.43	6950	3.2								
18.3	120	50	49.18	6420	3.2								
15.2	147	60	59.04	6820	3.4					TKM58B	71B5	7126	42
18.7	120	50	48.18	6370	4.2								



TKM..性能参数 PERFORMANCE PARAMETER

P _e [kW]	n _i [r/min]	M _e [Nm]	I		F _r [N]	fs			Page					
			公称 Nominal	实际 Actual										
0.37	23.3	140	125	120.34	2990	0.9	TKM28C	71B5/B14	7112	37				
	27.7	117	100	101.04	2820	0.9								
	38	87	75	74.62	2550	0.9								
	45	72	60	62.36	2400	1.8								
	53	61	50	52.36	2270	1.6								
	48	69	60	58.36	2350	1.9								
	57	58	50	48.86	2220	2.2								
	70	48	40	40.09	2070	2.7								
	95	35	30	29.33	1870	3.7								
	24.0	138	60	58.36	2960	0.9					TKM28B	71B5/B14	7124	36
	28.7	116	50	48.86	2790	1.1								
	35	95	40	40.09	2610	1.4								
	48	70	30	29.33	2350	1.9								
	58	57	25	24.07	2200	2.3								
	69	48	20	20.21	2080	2.1								
	94	35	15	14.92	1880	2.3								
	112	30	12.5	12.47	1770	4.4								
	134	25	10	10.47	1670	4.0								
	181	18.3	7.5	7.73	1510	4.4								
	22.4	148	40	40.09	3030	0.9	TKM28B	80B5/B14	8016	36				
	31	108	30	29.33	2730	1.2								
	37	89	25	24.07	2550	1.5								
	45	75	20	20.21	2410	1.3								
	60	55	15	14.92	2180	1.5								
	72	46	12.5	12.47	2050	2.8								
	86	39	10	10.47	1930	2.6								
	116	29	7.5	7.73	1750	2.8								
	18.5	176	150	151.56	3690	1.1					TKM38C	71B5/B14	7112	39
	22.9	142	125	122.22	3440	1.3								
	27.6	118	100	101.27	3230	1.3								
	38	85	75	73.33	2900	1.3								
	44	74	60	63.33	2760	2.4								
	53	61	50	52.48	2590	2.5								
	46	72	60	60.50	2720	2.8					TKM38B	71B5/B14	7112	38
	57	58	50	48.71	2530	3.5								
	71	47	40	39.29	2350	3.9								
	22.1	147	60	63.33	3480	1.2	TKM38C	71B5/B14	7124	39				
	26.7	122	50	52.48	3270	1.2								
	23.1	144	60	60.50	3430	1.4	TKM38B	71B5/B14	7124	38				
	28.7	116	50	48.71	3190	1.7								
	36	93	40	39.29	2970	1.9								
	46	72	30	30.31	2720	2.8								
	57	58	25	24.44	2530	3.1								
	69	48	20	20.25	2380	3.1								
	95	35	15	14.67	2130	3.2								
14.9	223	60	60.50	3970	0.9	TKM38B					80B5/B14	8016	38	
18.5	180	50	48.71	3690	1.1									
22.9	145	40	39.29	3440	1.2									
29.7	112	30	30.31	3150	1.8									
37	90	25	24.44	2930	2.0									
44	75	20	20.25	2760	2.0									
61	54	15	14.67	2470	2.0									
71	47	12.5	12.67	2360	3.8									
86	39	10	10.50	2210	3.9									
118	28	7.5	7.60	2090	3.9									
9.4	345	300	297.21	6320	1.0		TKM48C	71B5	7112	41				
11.6	280	250	240.89	5890	1.3									
14.0	233	200	200.66	5540	1.3									
18.5	176	150	151.20	5040	2.0									
22.2	146	125	125.95	4750	2.1									
28.2	115	100	99.22	4380	2.1									
37	88	75	75.45	4000	2.3									
45	72	60	62.43	3750	4.1									
57	57	50	49.18	3470	4.2									



TKM..性能参数 PERFORMANCE PARAMETER

P _{in} [kW]	n _i [r/min]	M _{in} [Nm]	I		F _z [N]	f _s			Page				
			公称 Nominal	实际 Actual									
0.37	9.3	351	150	151.20	6500	1.0	TKM48C	71B5	7124	41			
	11.1	292	125	125.95	5980	1.0							
	14.1	230	100	99.22	5520	1.0							
	18.6	175	75	75.45	5040	1.1							
	22.4	145	60	62.43	4730	2.1							
	28.5	114	50	49.18	4370	2.1							
	23.6	141	60	59.44	4660	2.5	TKM48B	71B5	7124	40			
	29.1	114	50	48.18	4340	3.1							
	35	95	40	40.13	4080	3.2							
	14.4	225	60	62.43	5480	1.3	TKM48C	80B5/B14	8016	41			
	18.3	178	50	49.18	5060	1.4							
	15.1	219	60	59.44	5390	1.6	TKM48B	80B5/B14	8016	40			
	18.7	178	50	48.18	5030	2.0							
	22.4	148	40	40.13	4730	2.0							
	29.8	112	30	30.24	4310	3.1							
	36	93	25	25.19	4050	3.2							
	45	73	20	19.84	3740	3.3							
	60	56	15	15.09	3410	3.6							
9.5	343	300	295.18	7990	1.5	TKM58C					71B5	7112	43
11.6	280	250	240.89	7470	1.8								
14.0	233	200	200.66	7030	2.1								
18.5	176	150	151.20	6390	2.8								
22.2	146	125	125.95	6010	3.3								
28.2	115	100	99.22	5550	3.3								
37	88	75	75.45	5070	3.4								
5.8	559	250	240.89	8300	0.9		TKM58C	71B5	7124	43			
7.0	466	200	200.66	8300	1.0								
9.3	351	150	151.20	8050	1.4								
11.1	292	125	125.95	7580	1.6								
14.1	230	100	99.22	7000	1.6								
18.6	175	75	75.45	6390	1.7								
22.4	145	60	62.43	6000	3.3								
28.5	114	50	49.18	5540	3.3								
23.7	140	60	59.04	5890	3.6	TKM58B	71B5	7124	42				
29.1	114	50	48.18	5500	4.4								
6.0	546	150	151.20	8300	0.9	TKM58C	80B5/B14	8016	43				
7.1	455	125	125.95	8300	1.1								
9.1	358	100	99.22	8110	1.1								
11.9	273	75	75.45	7400	1.1								
14.4	225	60	62.43	6950	2.1								
18.3	178	50	49.18	6420	2.1								
15.2	218	60	59.04	6820	2.3					TKM58B	80B5/B14	8016	42
18.7	178	50	48.18	6370	2.8								
22.4	148	40	40.13	6000	3.2								
0.55	45	108	60	62.43	2400	1.2	TKM28C	71B5/B14	7122	37			
	53	90	50	52.36	2270	1.1							
	48	103	60	58.36	2350	1.3	TKM28B	71B5/B14	7122	37			
	57	86	50	48.86	2220	1.5							
	70	71	40	40.09	2070	1.8							
	95	52	30	29.33	1870	2.5							
	116	42	25	24.07	1750	3.1							
	139	36	20	20.21	1650	2.8							
	188	26	15	14.92	1490	3.0							
	35	141	40	40.09	2610	0.9					TKM28B	80B5/B14	8014
	48	103	30	23.33	2350	1.3							
	58	85	25	24.07	2220	1.5							
	69	71	20	20.21	2080	1.4							
	94	53	15	14.92	1880	1.5							
	113	44	12.5	12.47	1770	3.0							
	134	37	10	10.47	1670	2.7							
	181	27	7.5	7.73	1510	2.9							



TKM..性能参数 PERFORMANCE PARAMETER

P _s [kW]	n _i [r/min]	M _{in} [Nm]	I 公称 Nominal	I 实际 Actual	F _z [N]	fs			Page					
										← →				
0.55	37	132	25	24.07	2550	1.0	TKM28B	80B5/B14	8026	36				
	45	111	20	20.21	2410	0.9								
	60	82	15	14.92	2180	1.0								
	72	68	1205	12.47	2050	1.9								
	86	57	10	10.47	1930	1.7								
	116	42	7.5	7.73	1750	1.9								
	22.9	211	125	122.22	3440	0.9					TKM38C	71B5/B14	7122	39
	27.6	175	100	101.27	3230	0.9								
	38	127	75	73.33	2900	0.9								
	44	109	60	63.33	2760	1.6								
53	91	50	52.48	2590	1.7	TKM38B	71B5/B14	7122	38					
46	107	60	60.50	2720	1.9									
57	86	50	48.71	2530	2.3									
71	69	40	39.29	2350	2.6									
92	53	30	30.31	2160	3.7									
23.1	213	60	60.50	3430	0.9					TKM38B	80B5/B14	8014	38	
28.7	172	50	48.71	3190	1.2									
36	139	40	39.29	2970	1.3									
46	107	30	30.31	2720	1.9									
57	86	25	24.44	2530	2.1									
69	71	20	20.25	2380	2.1									
95	52	15	14.67	2130	2.1									
110	45	12.5	12.67	2030	4.0									
133	37	10	10.50	1910	4.1									
184	27	7.5	7.60	1710	4.1	TKM38B	80B5/B14	8026	38					
22.9	216	40	39.29	3440	0.8									
29.7	166	30	30.31	3150	1.2									
37	134	25	24.44	2930	1.3									
44	111	20	20.25	2760	1.4									
61	80	15	14.67	2470	1.4									
71	70	12.5	12.67	2360	2.6									
86	58	10	10.50	2210	2.6									
118	42	7.5	7.60	1990	2.6									
14.0	346	200	200.66	5540	0.9					TKM48C	71B5	7122	41	
18.5	261	150	151.20	5040	1.3									
22.2	217	125	125.95	4750	1.4									
28.2	171	100	99.22	4380	1.4									
37	130	75	75.45	4000	1.5									
45	108	60	62.43	3750	2.8									
57	85	50	49.18	3470	2.8	TKM48B	71B5	7122	40					
47	105	60	59.44	3690	3.3									
58	85	50	48.18	3440	4.1									
70	71	40	40.13	3240	4.2									
18.6	260	75	75.45	5040	0.8	TKM48C	80B5/B14	8014	41					
22.4	215	60	62.43	4730	1.4									
28.5	170	50	49.18	4370	1.4									
23.6	210	60	59.44	4660	1.7	TKM48B	80B5/B14	8014	40					
29.1	170	50	48.18	4340	2.1									
35	142	40	40.13	4080	2.1									
46	107	30	30.24	3720	3.3									
56	89	25	25.19	3500	3.4									
71	70	20	19.84	3230	3.4									
93	53	15	15.09	2950	3.8									
14.4	335	60	62.43	5480	0.9					TKM48C	80B5/B14	8026	41	
18.3	264	50	49.18	5060	0.9									
15.1	326	60	59.44	5390	1.1					TKM48B	80B5/B14	8026	40	
18.7	264	50	48.18	5030	1.3									
22.4	220	40	40.13	4730	1.4									
29.8	166	30	30.24	4310	2.1									
36	138	25	25.19	4050	2.2									
45	109	20	19.84	3740	2.2									
60	83	15	15.09	3410	2.4									



TKM..性能参数 PERFORMANCE PARAMETER

P _s [kW]	n _i [r/min]	M _s [Nm]	I		F _r [N]	f _s			Page					
			公称 Nominal	实际 Actual										
0.55	9.5	509	300	295.18	7990	1.0	TKM58C	71B5	7122	43				
	11.6	416	250	240.89	7470	1.2								
	14.0	346	200	200.66	7030	1.4								
	18.5	261	150	151.20	6390	1.9								
	22.2	217	125	125.95	6010	2.2								
	28.2	171	100	99.22	5550	2.2								
	37	130	75	75.45	5070	2.3	TKM58C	80B5/B14	8014	43				
	45	108	60	62.43	4760	4.5								
	57	85	50	49.18	4390	4.5								
	9.3	522	150	151.20	8050	1.0								
	11.1	435	125	125.95	7580	1.1								
	14.1	342	100	99.22	7000	1.1								
	18.6	260	75	75.45	6390	1.2	TKM58B	80B5/B14	8014	42				
	22.4	215	60	62.43	6000	2.2								
	28.5	170	50	49.18	5540	2.2								
	23.7	208	60	59.04	5890	2.4								
	29.1	170	50	48.18	5500	2.9								
	35	142	40	40.13	5170	3.4								
	14.4	335	60	62.43	6950	1.4	TKM58C	80B5/B14	8026	43				
	18.3	264	50	49.18	6420	1.4								
	15.2	324	60	59.04	6820	1.5					TKM58B	80B5/B14	8026	42
	18.7	264	50	48.18	6370	1.9								
	22.4	220	40	40.13	6000	2.2								
	29.8	166	30	30.24	5460	3.0								
36	138	25	25.19	5130	3.5									
45	109	20	19.84	4740	3.5	TKM28B	80B5/B14	8012	36					
60	83	15	15.09	4330	3.6									
48	140	60	58.36	2350	0.9									
57	117	50	48.86	2220	1.1									
70	96	40	40.09	2070	1.3									
95	71	30	29.33	1870	1.8									
116	58	25	24.07	1750	2.2	TKM28B	80B5/B14	8024	36					
139	49	20	20.21	1650	2.1									
188	36	15	14.92	1490	2.2									
225	30	12.5	12.47	1400	4.3									
267	25	10	10.47	1320	4.0									
362	18.6	7.5	7.73	1200	4.3									
48	141	30	29.33	2350	0.9	TKM28B	80B5/B14	8024	36					
58	116	25	24.07	2200	1.1									
69	97	20	20.21	2080	1.0									
94	72	15	14.92	1880	1.1									
112	60	12.5	12.47	1770	2.2									
134	50	10	10.47	1670	2.0									
181	37	7.5	7.73	1510	2.2	TKM28B	90B5/B14	90S6	36					
72	93	12.5	12.47	2050	1.4									
86	78	10	10.47	1930	1.3									
116	58	7.5	7.73	1750	1.4									
44	149	60	63.33	2760	1.2					TKM38C	80B5/B14	8012	39	
53	124	50	52.48	2590	1.2									
46	145	60	60.50	2720	1.4	TKM38B	80B5/B14	8012	38					
57	117	50	48.71	2530	1.7									
71	94	40	39.29	2350	1.9									
92	73	30	30.31	2160	2.7									
115	59	25	24.44	2010	3.1									
138	49	20	20.25	1890	3.1									
191	35	15	14.67	1690	3.1	TKM38B	80B5/B14	8024	38					
28.7	234	50	48.71	3190	0.9									
36	189	40	39.29	2970	1.0									
46	146	30	30.31	2720	1.4									
57	118	25	24.44	2530	1.5									
69	97	20	20.25	2380	1.5									
95	71	15	14.67	2130	1.6									
110	61	12.5	12.67	2030	3.0									
133	50	10	10.50	1910	3.0									
184	37	7.5	7.60	1710	3.0									



TKM..性能参数 PERFORMANCE PARAMETER

P _e [kW]	n _i [r/min]	M _e [Nm]	I		F _z [N]	fs			Page					
			公称 Nominal	实际 Actual										
0.75	29.7	227	30	30.31	3150	0.9	TKM38B	90B5/B14	90S6	38				
	37	183	25	24.44	2930	1.0								
	44	151	20	20.25	2760	1.0								
	61	110	15	14.67	2470	1.0								
	71	95	12.5	12.67	2360	1.9								
	86	79	10	10.50	2210	1.9								
	118	57	7.5	7.60	1990	1.9								
	18.5	356	150	151.20	5040	1.0					TKM48C	80B5/B14	80I2	41
	22.2	296	125	125.95	4750	1.0								
	28.2	234	100	99.22	4380	1.0								
37	178	75	75.45	4000	1.1									
45	147	60	62.43	3750	2.0									
57	116	50	49.18	3470	2.1									
47	143	60	62.43	3690	2.4	TKM48B	80B5/B14	80I2	40					
58	116	50	49.18	3440	3.0									
70	96	40	59.44	3240	3.1									
22.4	294	60	48.18	4730	1.0	TKM48C	80B5/B14	8024	41					
28.5	231	50	40.13	4370	1.0									
23.6	286	60	30.24	4660	1.2	TKM48B	80B5/B14	8024	40					
29.1	232	50	25.19	4340	1.5									
35	193	40	19.84	4080	1.6									
46	145	30	15.09	3720	2.4									
56	121	25	48.18	3500	2.5									
71	95	20	40.13	3230	2.5									
93	73	15	30.24	2950	2.8									
18.7	360	50	19.84	5030	1.0					TKM48B	90B5/B14	90S6	40	
22.4	300	40	15.09	4730	1.0									
29.8	226	30	12.49	4310	1.5									
36	188	25	9.84	4050	1.6									
45	148	20	7.48	3740	1.6									
60	113	15	240.89	3410	1.8									
72	93	12.5	200.66	3210	3.2									
91	74	10	151.20	2960	3.3									
120	56	7.5	125.95	2700	3.6									
11.6	567	250	99.22	7470	0.9	TKM58C	80B5/B14	80I2	43					
14.0	472	200	75.45	7030	1.0									
18.5	356	150	62.43	6390	1.4									
22.2	296	125	49.18	6010	1.6									
28.2	234	100	59.04	5550	1.6									
37	178	75	48.18	5070	1.7									
45	147	60	62.43	4760	3.3									
57	116	50	49.18	5390	3.3									
47	142	60	59.04	4670	3.5					TKM58B	80B5/B14	80I2	42	
58	116	50	48.18	4360	4.3									
22.4	294	60	62.43	6000	1.6	TKM58C	80B5/B14	8024	43					
28.5	231	50	49.18	5540	1.6									
23.7	284	60	59.04	5890	1.8	TKM58B	80B5/B14	8024	42					
29.1	232	50	48.18	5500	2.2									
35	193	40	40.13	5170	2.5									
46	145	30	30.24	4710	3.4									
56	121	25	25.19	4430	4.0									
71	95	20	19.84	4090	4.0									
93	73	15	15.09	3730	4.1									
14.4	457	60	62.43	6950	1.1					TKM58C	90B5/B14	90S6	43	
18.3	360	50	49.18	6420	1.1									
15.2	442	60	59.04	6820	1.1	TKM58B	90B5/B14	90S6	42					
18.7	360	50	48.18	6370	1.4									
22.4	300	40	40.13	6000	1.6									
29.8	226	30	30.24	5460	2.2									
36	188	25	25.19	5130	2.5									
45	148	20	19.84	4740	2.6									
60	113	15	15.09	4330	2.7									



TKM..性能参数 PERFORMANCE PARAMETER

P _{in} [kW]	n _i [r/min]	M _{in} [Nm]	I		F _z [N]	fs			Page					
			公称 Nominal	实际 Actual										
1.1	70	141	40	40.09	2070	0.9	TKM28B	80B5/B14	8022	36				
	95	103	30	29.33	1870	1.3								
	116	85	25	24.07	1750	1.5								
	139	71	20	20.21	1650	1.4								
	188	53	15	14.92	1490	1.5								
	225	44	12.5	12.47	1400	3.0								
	267	37	10	10.47	1320	2.7								
	362	27	7.5	7.73	1200	2.9								
	112	88	12.5	12.47	1770	1.5					TKM28B	90B5/B14	90S4	36
	134	74	10	10.47	1670	1.4								
181	55	7.5	7.73	1510	1.5									
72	137	12.5	12.47	2050	1.0	TKM28B	90B5/B14	90L6	36					
86	115	10	10.47	1930	0.9									
116	85	7.5	7.73	1750	0.9									
46	213	60	60.50	2720	0.9					TKM38B	80B5/B14	8022	38	
57	172	50	48.71	2530	1.2									
71	139	40	39.29	2350	1.3									
92	107	30	30.31	2160	1.9									
115	86	25	24.44	2010	2.1									
138	71	20	20.25	1890	2.1									
191	52	15	14.67	1690	2.1									
221	45	12.5	12.67	1610	4.0									
267	37	10	10.50	1510	4.1									
368	27	7.5	7.60	1360	4.1									
46	214	30	30.31	2720	0.9	TKM38B	90B5/B14	90S4	38					
57	172	25	24.44	2530	1.0									
69	143	20	20.25	2380	1.1									
95	103	15	14.67	2130	1.1									
110	89	12.5	12.67	2030	2.0									
133	74	10	10.50	1910	2.0									
184	54	7.5	7.60	1710	2.1									
71	139	12.5	12.67	2360	1.3	TKM38B	90B5/B14	90L6	38					
86	115	10	10.50	2210	1.3									
118	83	7.5	7.60	1990	1.3									
45	215	60	62.43	3750	1.4	TKM48C	80B5/B14	8022	41					
57	170	50	49.18	3470	1.4									
47	210	60	59.44	3690	1.7	TKM48B	80B5/B14	8022	40					
58	170	50	48.18	3440	2.1									
70	142	40	40.13	3240	2.1									
93	107	30	30.24	2950	3.3									
111	89	25	25.19	2770	3.4									
141	70	20	19.84	2560	3.4									
186	53	15	15.09	2340	3.8									
29.1	340	50	48.18	4340	1.0					TKM38B	90B5/B14	90S4	40	
35	283	40	40.13	4080	1.1									
46	213	30	30.24	3720	1.6									
56	178	25	25.19	3500	1.7									
71	140	20	19.84	3230	1.7									
93	106	15	15.09	2950	1.9									
112	88	12.5	12.49	2770	3.4									
142	69	10	9.84	2550	3.5									
187	53	7.5	7.48	2330	3.8									
29.8	332	30	30.24	4310	1.1	TKM48B	90B5/B14	90L6	40					
36	276	25	25.19	4050	1.1									
45	218	20	19.84	3740	1.1									
60	166	15	15.09	3410	1.2									
72	137	12.5	12.49	3210	2.2									
91	108	10	9.84	2960	2.2									
120	82	7.5	7.48	2700	2.4									
18.5	522	150	151.20	6390	1.0					TKM58C	80B5/B14	8022	43	
22.2	435	125	125.95	6010	1.1									
28.2	342	100	99.22	5550	1.1									
37	260	75	75.45	5070	1.2									
45	215	60	62.43	4760	2.2									
57	170	50	49.18	4390	2.2									



TKM..性能参数 PERFORMANCE PARAMETER

P _s [kW]	n _i [r/min]	M _s [Nm]	I		F _z [N]	fs			Page					
			公称 Nominal	实际 Actual										
1.1	47	208	60	59.04	4670	2.4	TKM58B	80B5/B14	8022	42				
	58	170	50	48.18	4360	2.9								
	70	142	40	40.13	4110	3.4								
	22.4	431	60	62.43	6000	1.1	TKM58C	90B5/B14	90S4	43				
	28.5	340	50	49.18	5540	1.1								
	23.7	416	60	59.04	5890	1.2								
	29.1	340	50	48.18	5500	1.5	TKM58B	90B5/B14	90S4	42				
	35	283	40	40.13	5170	1.7								
	46	213	30	30.24	4710	2.3								
	56	178	25	25.19	4430	2.7								
	71	140	20	19.84	4090	2.7								
	93	106	15	15.09	3730	2.8								
	18.7	529	50	48.18	6370	0.9					TKM58B	90B5/B14	90L6	42
	22.4	440	40	40.13	6000	1.1								
	29.8	332	30	30.24	5460	1.5								
	36	276	25	25.19	5130	1.7								
	45	218	20	19.84	4740	1.7								
	60	166	15	15.09	4330	1.8								
72	137	12.5	12.49	4060	3.5									
91	108	10	9.84	3750	3.5									
120	82	7.5	7.48	3420	3.7									
1.5	95	141	30	29.33	1870	0.9	TKM28B	90B5/B14	90S2	36				
	116	116	25	24.07	1750	1.1								
	139	97	20	20.21	1650	1.0								
	188	72	15	14.92	1490	1.1								
	225	60	12.5	12.47	400	2.2								
	267	50	10	10.47	1320	2.0								
	362	37	7.5	7.73	1200	2.2								
	112	120	12.5	12.47	1770	1.1	TKM28B	90B5/B14	90L4	36				
	134	101	10	10.47	1670	1.0								
	181	74	7.5	7.73	1510	1.1								
	57	234	50	48.71	2530	0.9	TKM38B	90B5/B14	90S2	38				
	71	189	40	39.29	2350	1.0								
	92	146	30	30.31	2160	1.4								
	115	118	25	24.44	2010	1.5								
	138	97	20	20.25	1890	1.5								
	191	71	15	14.67	1690	1.6								
	221	61	12.5	12.67	1610	3.0								
	267	50	10	10.50	1510	3.0								
	368	37	7.5	7.60	1360	3.0								
	57	235	25	24.44	2530	0.8					TKM38B	90B5/B14	90L4	38
	69	195	20	20.25	2380	0.8								
	95	141	15	14.67	2130	0.8								
	110	122	12.5	12.67	2030	1.5								
	133	101	10	10.50	1910	1.5								
	184	73	7.5	7.60	1710	1.5								
	45	294	60	62.43	3750	1.0	TKM48C	90B5/B14	90S2	41				
	57	231	50	49.18	3470	1.0								
	47	286	60	59.44	3690	1.2	TKM48B	90B5/B14	90S2	40				
	58	232	50	48.18	3440	1.5								
	70	193	40	40.13	3240	1.6								
	93	145	30	30.24	2950	2.4								
	111	121	25	25.19	2770	2.5								
	141	95	20	19.84	2560	2.5								
	196	79	15	15.09	2340	2.8								
	35	386	40	40.13	4080	0.8					TKM48B	90B5/B14	90L4	40
	46	291	30	30.24	3720	1.2								
56	242	25	25.19	3500	1.2									
71	191	20	19.84	3230	1.3									
93	145	15	15.09	2950	1.4									
112	120	12.5	12.49	2770	2.5									
142	95	10	9.84	2550	2.5									
187	72	7.5	7.48	2330	2.8									
45	297	20	19.84	3740	0.8	TKM48B	100B5/B14	100L6	40					
60	226	15	15.09	3410	0.9									
72	187	12.5	12.49	3210	1.6									
91	147	10	9.84	2960	1.6									
120	112	7.5	7.48	2700	1.8									

TKM..性能参数 PERFORMANCE PARAMETER

P _e [kW]	n _i [r/min]	M _{in} [Nm]	I		F _r [N]	fs			Page					
			公称 Nominal	实际 Actual										
1.5	45	294	60	62.43	4760	1.6	TKM58C	90B5/B14	90S2	43				
	57	231	50	49.18	4390	1.6								
	47	284	60	59.04	4670	1.8					TKM58B	90B5/B14	90S2	42
	58	232	50	48.18	4360	2.2								
	70	193	40	40.13	4110	2.5								
	93	145	30	30.24	3740	3.4								
	111	121	25	25.19	3520	4.0								
	141	95	20	19.84	3250	4.0								
	186	73	15	15.09	2960	4.1	TKM58B	90B5/B14	90L4	42				
	23.7	568	60	59.04	5890	0.9								
	29.1	463	50	48.18	5500	1.1								
	35	386	40	40.13	5170	1.2								
	46	291	30	30.24	4710	1.7								
	56	242	25	25.19	4430	2.0								
	71	191	20	19.84	4090	2.0								
	93	145	15	15.09	3730	2.1								
	112	120	12.5	12.49	3510	4.0								
	142	95	10	9.84	3240	4.0								
187	72	7.5	7.48	2950	4.2									
29.8	452	30	30.24	5460	1.1	TKM58B					100B5/B14	90L6	42	
36	377	25	25.19	5130	1.3									
45	297	20	19.84	4740	1.3									
60	226	15	15.09	4330	1.3									
72	187	12.5	12.49	4060	2.6									
91	147	10	9.84	3750	2.6									
120	112	7.5	7.48	3420	2.7									
225	88	12.5	12.47	1400	1.5		TKM28B	90B5/B14	90L2	36				
267	74	10	10.47	1320	1.4									
362	55	7.5	7.73	1200	1.5									
2.2	92	214	30	30.31	2160	0.9	TKM38B	90B5/B14	90L2	40				
	115	172	25	24.44	2010	1.0								
	138	143	20	20.25	1890	1.1								
	191	103	15	14.67	1690	1.1								
	221	89	12.5	12.67	1610	2.0								
	267	74	10	10.50	1510	2.0								
	368	54	7.5	7.60	1360	2.1	TKM48B	90B5/B14	90L2	40				
	58	340	50	48.18	3440	1.0								
	70	283	40	40.13	3240	1.1								
	93	213	30	30.24	2950	1.6								
	111	178	25	25.19	2770	1.7								
	141	140	20	19.84	2560	1.7								
	186	106	15	15.09	2340	1.9								
	224	88	12.5	12.49	2190	3.4								
	285	69	10	9.84	2030	3.5								
	374	53	7.5	7.48	1850	3.8								
	56	355	25	25.19	3500	0.8					TKM48B	100B5/B14	100LA4	40
	71	280	20	19.84	3230	0.9								
93	213	15	15.09	2950	0.9									
112	176	12.5	12.49	2770	1.7									
142	139	10	9.84	2550	1.7									
187	106	7.5	7.48	2330	1.9									
72	274	12.5	12.49	3210	1.1	TKM48B	112B5/B14	112M6	40					
91	216	10	9.84	2960	1.1									
120	164	7.5	7.48	2700	1.2									
45	431	60	62.43	4760	1.1	TKM58C	90B5/B14	90L2	43					
57	340	50	49.18	4390	1.1									
47	416	60	59.04	4670	1.2	TKM58B	90B5/B14	90L2	42					
58	340	50	48.18	4360	1.5									
70	283	40	40.13	4110	1.7									
93	213	30	30.24	3740	2.3									
111	178	25	25.19	3520	2.7									
141	140	20	19.84	3250	2.7									
186	106	15	15.09	2960	2.8	TKM58B	100B5/B14	100LA4	42					
35	566	40	40.13	5170	0.8									
46	427	30	30.24	4710	1.2									
56	355	25	25.19	4430	1.4									
71	280	20	19.84	4090	1.4									

TKM..性能参数 PERFORMANCE PARAMETER

P _{in} [kW]	n _i [r/min]	M _{in} [Nm]	I		F _z [N]	fs			Page				
			公称 Nominal	实际 Actual									
2.2	93	213	15	15.09	3730	1.4	TKM58B	100B5/B14	100LA4	42			
	112	176	12.5	12.49	3510	2.7							
	142	139	10	9.84	3240	2.7							
	187	106	7.5	7.48	2950	2.8							
	36	553	25	25.19	5130	0.9	TKM58B	112B5/B14	112M4	42			
	45	435	20	19.84	4740	0.9							
	60	331	15	15.09	4330	0.9							
	72	274	12.5	12.49	4060	1.8							
	91	216	10	9.84	3750	1.8							
	120	164	7.5	7.48	3420	1.8							
	3.0	70	386	40	40.13	3240	0.8	TKM48B	100B5/B14	100L2	40		
		93	291	30	30.24	2950	1.2						
111		242	25	25.19	2770	1.2							
141		191	20	19.84	2560	1.3							
186		145	15	15.09	2340	1.4							
224		120	12.5	12.49	2190	2.5							
285		95	10	9.84	2030	2.5							
374		72	7.5	7.48	1850	2.8							
112		240	12.5	12.49	2770	1.2	TKM48B	100B5/B14	100LB2	40			
142		189	10	9.84	2550	1.3							
187		144	7.5	7.48	2330	1.4							
47		568	60	59.04	4670	0.9	TKM58B	100B5/B14	100L2	42			
58		463	50	48.18	4360	1.1							
70		386	40	40.13	4110	1.2							
93		291	30	30.24	3740	1.7							
111		242	25	25.19	3520	2.0							
141		191	20	19.84	3250	2.0							
186		145	15	15.09	2960	2.1							
224	120	12.5	12.49	2780	4.0								
285	95	10	9.84	2570	4.0								
374	72	7.5	7.48	2340	4.2								
46	582	30	30.24	4710	0.9	TKM58B					100B5/B14	100LB2	42
56	485	25	25.19	4430	1.2								
71	382	20	19.84	4090	1.0								
93	290	15	15.09	3730	1.0								
112	240	12.5	12.49	3510	2.0								
142	189	10	9.84	3240	2.0								
187	144	7.5	7.48	2950	2.1								
4.0	93	388	30	30.24	2950	0.9	TKM48B	112B5/B14	112M2	40			
	111	323	25	25.19	2770	0.9							
	141	254	20	19.84	2560	0.9							
	186	194	15	15.09	2340	1.0							
	224	160	12.5	12.49	2190	1.9							
	285	126	10	9.84	2030	1.9							
	374	96	7.5	7.48	1850	2.1							
	112	320	12.5	12.49	2770	0.9	TKM48B	112B5/B14	112M4	40			
	142	252	10	9.84	2550	1.0							
	187	192	7.5	7.48	2330	1.0							
	70	515	40	40.13	4110	0.9	TKM58B	112B5/B14	112M2	42			
	93	388	30	30.24	3740	1.3							
	111	323	25	25.19	3520	1.5							
	141	254	20	19.84	3250	1.5							
	186	194	15	15.09	2960	1.6							
	224	160	12.5	12.49	2780	3.0							
	285	126	10	9.84	2570	3.0							
	374	96	7.5	7.48	2340	3.1							
112	320	12.5	12.49	3510	1.5	TKM58B					112B5/B14	112M4	45
142	252	10	7.84	3240	1.5								
187	192	7.5	7.48	2950	1.6								

TKM..性能参数 PERFORMANCE PARAMETER

$n_1=1400r/min$

M_{2max} [Nm]	n_2 [r/min]	I 公称 Nominal	I 实际 Actual	P_{95} [kW]	F_{t2} [N]	F_{t1} [N]		Page ←→
130	4.8	300	291.79	0.07	4100	400	TKM28C..HS	54
130	5.7	250	244.29	0.08	4100	400		
130	7.0	200	200.44	0.10	4100	400		
130	9.5	150	146.67	0.14	4000	400		
130	11.6	125	120.34	0.17	3770	400		
100	13.9	100	101.04	0.16	3560	400		
80	18.8	75	74.62	0.17	3220	400		
130	22.5	60	62.36	0.33	3030	400		
100	27	50	52.36	0.30	2860	400		
130	24	60	58.36	0.35	2960	400		
130	29	50	48.86	0.41	2790	400		
130	35	40	40.09	0.51	2610	400		
130	48	30	29.33	0.69	2350	400		
130	58	25	24.07	0.84	2200	400		
100	69	20	20.21	0.77	2080	400		
80	94	15	14.92	0.84	1880	400		
130	112	12.5	12.47	1.6	1770	400		
100	134	10	10.47	1.5	1670	400		
80	181	7.5	7.73	1.6	1510	400		
200	4.6	300	302.50	0.11	4800	400	TKM38C..HS	54
200	5.7	250	243.57	0.13	4800	400		
180	7.1	200	196.43	0.15	4800	400		
200	9.2	150	151.56	0.21	4650	400		
180	11.5	125	122.22	0.23	4330	400		
150	13.8	100	101.27	0.24	4070	400		
110	19.1	75	73.33	0.24	3650	400		
180	22	60	63.33	0.45	3480	400		
150	27	50	52.48	0.46	3270	400		
200	23	60	60.50	0.52	3430	530		
200	29	50	48.71	0.64	3190	530		
180	36	40	39.29	0.71	2970	530		
200	46	30	30.31	1.0	2720	530		
180	57	25	24.44	1.1	2530	530		
150	69	20	20.25	1.2	2380	530		
110	95	15	14.67	1.2	2130	530		
180	110	12.5	12.67	2.2	2030	530		
150	133	10	10.50	2.2	1910	530		
110	184	7.5	7.60	2.3	1710	530		

TKM..性能参数 PERFORMANCE PARAMETER

$n_1=1400r/min$

M_2_{max} [Nm]	n_2 [r/min]	I 公称 Nominal	I 实际 Actual	P_{95} [kW]	F_{t2} [N]	F_{r1} [N]		Page ↔
350	4.7	300	297.21	0.19	6500	560	TKM48C..HS	54
350	5.8	250	240.89	0.23	6500	560		
300	7.0	200	200.66	0.24	6500	560		
350	9.3	150	151.20	0.37	6500	560		
300	11.1	125	125.95	0.38	5980	560		
240	14.1	100	99.22	0.39	5520	560		
200	18.6	75	75.45	0.42	5040	560		
300	22	60	62.43	0.77	4730	560		
240	28	50	49.18	0.78	4370	560		
350	24	60	59.44	0.92	4660	860		
350	29	50	48.18	1.1	4340	860		
300	35	40	40.13	1.2	4080	860		
350	46	30	30.24	1.8	3720	860		
300	56	25	25.19	1.9	3500	860		
240	71	20	19.84	1.9	3230	860		
200	93	15	15.09	2.1	2950	860		
300	112	12.5	12.49	3.7	2770	860		
240	142	10	9.84	3.8	2550	860		
200	187	7.5	7.48	4.2	2330	860		
500	4.7	300	295.18	0.27	8300	560	TKM58B..HS	54
500	5.8	250	240.89	0.33	8300	560		
480	7.0	200	200.66	0.38	8300	560		
500	9.3	150	151.20	0.53	8050	560		
480	11.1	125	125.95	0.61	7580	560		
380	14.1	100	99.22	0.61	7000	560		
300	18.6	75	75.45	0.63	6390	560		
480	22	60	62.43	1.2	6000	560		
380	28	50	49.18	1.2	5540	560		
500	24	60	59.04	1.3	5890	1260	TKM58C..HS	54
500	29	50	48.18	1.6	5500	1260		
480	35	40	40.13	1.9	5170	1260		
500	46	30	30.24	2.6	4710	1260		
480	56	25	25.19	3.0	4430	1260		
380	71	20	19.84	3.0	4090	1260		
300	93	15	15.09	3.1	3730	1260		
480	112	12.5	12.49	6.0	3510	1260		
380	142	10	9.84	6.0	3240	1260		
300	187	7.5	7.48	6.3	2950	1260		

TKM..(IEC)外形尺寸图表 OUTLINE DIMENSION SHEET

TKM28B..

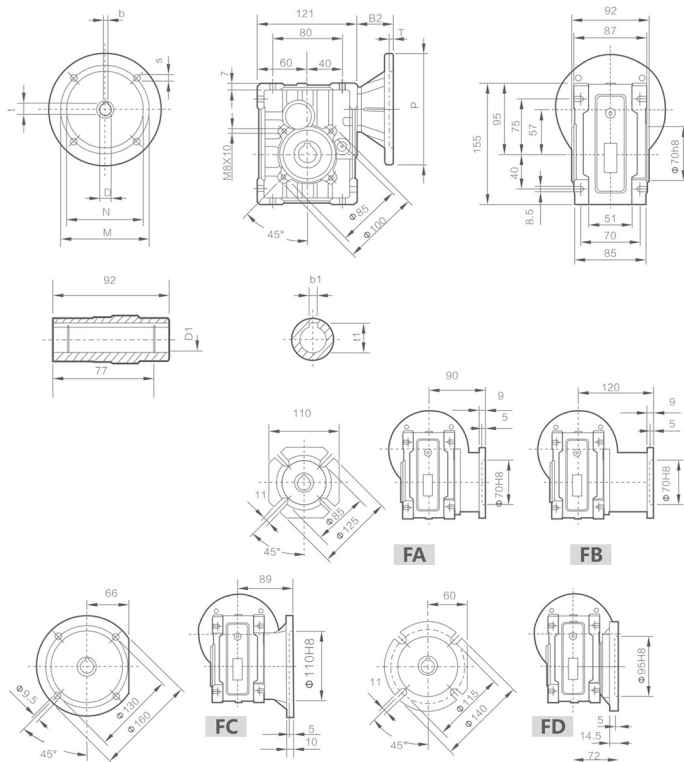

IEC	DE8	b	t	P	M	N	S	T	L	D1 _{IEC}	b1	t1
63B5	11	4	12.8	140	115	95	9	4	106	20*	6*	22.8*
71B5	14	5	16.3	160	130	110	9	4	113	24*	8*	27.3*
71B14	14	5	16.3	105	85	70	7	4	113	25	8	28.3
80B5	19	6	21.8	200	165	130	11	4	133	*非标产品, 订单时请说明 *Only on request		
80B14	19	6	21.8	120	100	80	7	4	133	重量 (不包括马达) ≈4.2kg		
90B14	24	8	27.3	140	115	95	9	4	133	Weight without motor ≈4.2kg		

TKM...(IEC)外形尺寸图表 OUTLINE DIMENSION SHEET

TKM28C..

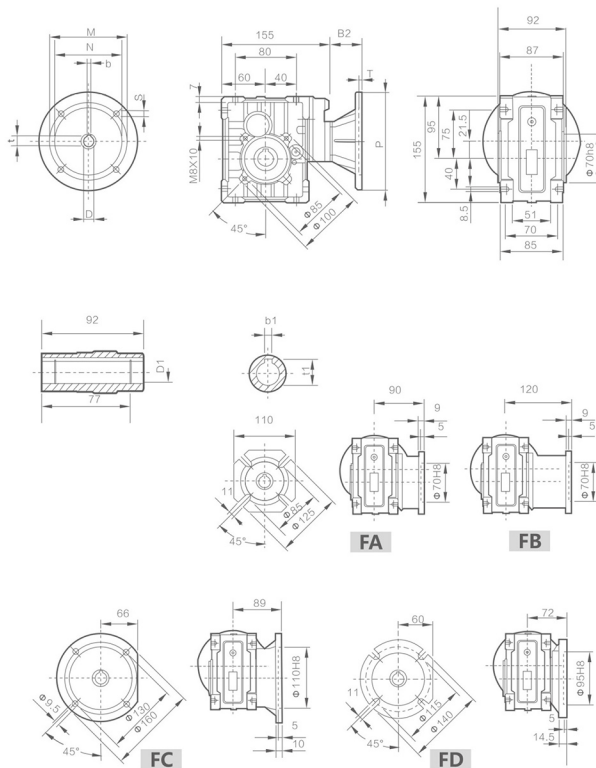

IEC	DE8	b	t	P	M	N	S	T	L	D1 _{IE}	b1	t1
63B5	11	4	12.8	140	115	95	9	4	140	20*	6*	22.8*
71B5	14	5	16.3	160	130	110	9	4	147	24*	8*	27.3*
71B14	14	5	16.3	105	85	70	7	4	147	25	8	28.3

*非标产品，订单时请说明
 *Only on request
 重量 (不包括马达)
 ≈5kg
 Weight without motor
 ≈5kg

TKM...(IEC)外形尺寸图表 OUTLINE DIMENSION SHEET

TKM38B..

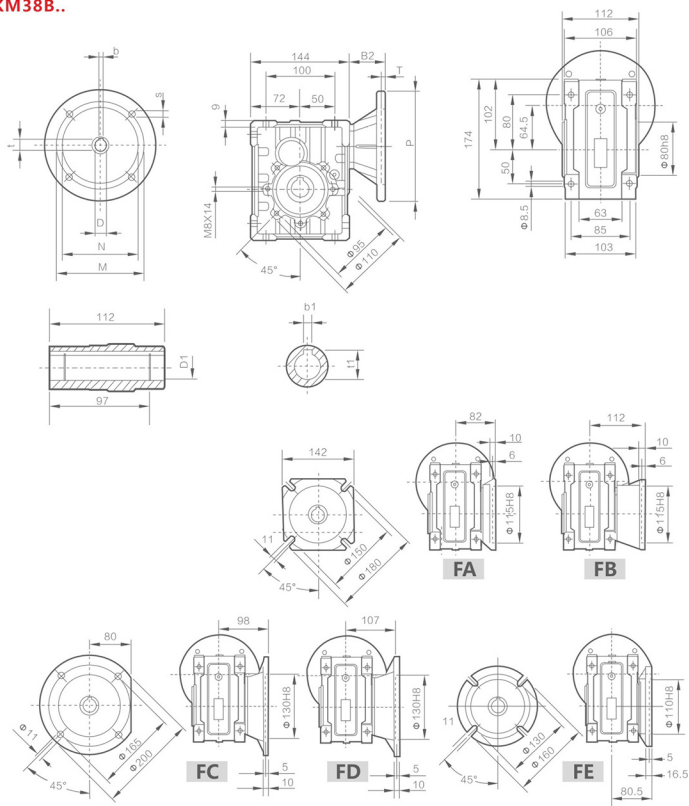

IEC	DE8	b	t	P	M	N	S	T	L	D1 _{H8}	b1	t1
63B5	11	4	12.8	140	115	95	9	4	117	25	8	28.3
71B5	14	5	16.3	160	130	110	9	4	124	28	8	31.3
71B14	14	5	16.3	105	85	70	7	4	124	30	8	33.3
80B5	19	6	21.8	200	165	130	11	4	144			
80B14	19	6	21.8	120	100	80	7	4	144			
90B5	24	8	27.3	200	165	130	11	4	144			
90B14	24	8	27.3	140	115	95	9	4	144			

*非标产品，订单时请说明
*Only on request
重量 (不包括马达)
≈6.0kg
Weight without motor
≈6.0kg

TKM..(IEC)外形尺寸图表 OUTLINE DIMENSION SHEET

TKM38C..

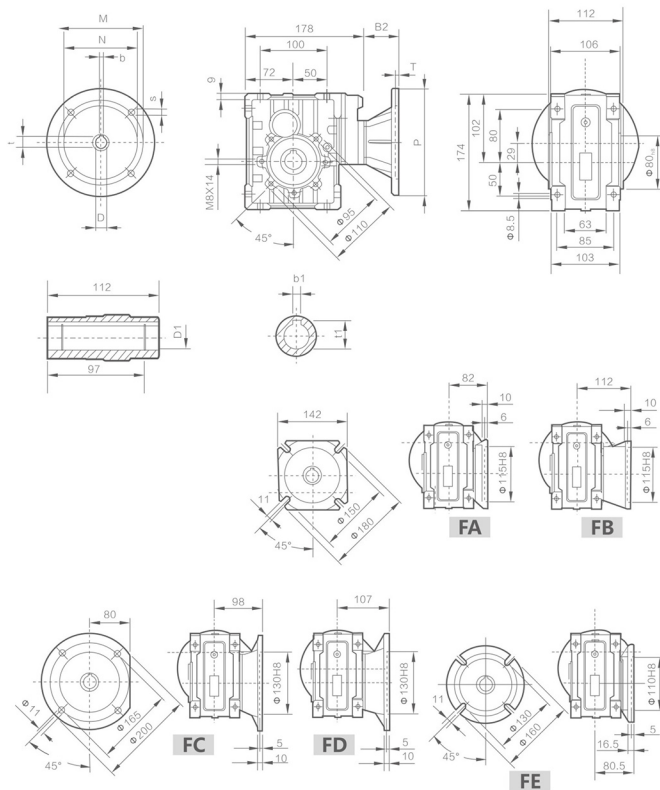

IEC	DE8	b	t	P	M	N	S	T	L	D1 _±	b1	t1
63B5	11	4	12.8	140	115	95	9	4	151	25	8	28.3
71B5	14	5	16.3	160	130	110	9	4	158	28	8	31.3
71B14	14	5	16.3	105	85	70	7	4	158	30	8	33.3
80B5	19	6	21.8	200	165	130	11	4	178	*非标产品, 订单时请说明 *Only on request 重量 (不包括马达) ≈6.0kg Weight without motor ≈6.0kg		
80B14	19	6	21.8	120	100	80	7	4	178			

TKM...(IEC)外形尺寸图表 OUTLINE DIMENSION SHEET

TKM48B..

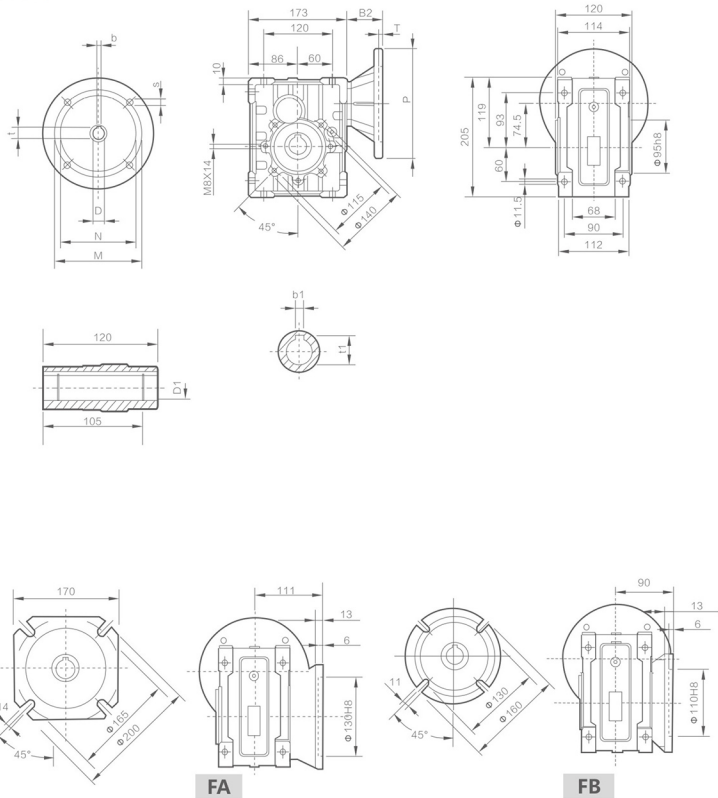

FA

FB

IEC	DE8	b	t	P	M	N	S	T	L	D1 _{ie}	b1	t1
71B5	14	5	16.3	160	130	110	9	4	146	28	8	31.3
80B5	19	6	21.8	200	165	130	11	4	166	30*	8*	33.3*
80B14	19	6	21.8	120	100	80	7	4	166	35*	10*	38.3*
90B5	24	8	27.3	200	165	130	11	4	166	*非标产品, 订单时请说明		
90B14	24	8	27.3	140	115	95	9	4	166	*Only on request		
100/112B5	28	8	31.3	250	215	180	13.5	4.5	176	重量 (不包括马达)		
100/112B14	28	8	31.3	160	130	110	9	4.5	176	≈9.2kg		
										Weight without motor		
										≈9.2kg		

TKM...(IEC)外形尺寸图表 OUTLINE DIMENSION SHEET

TKM48C..

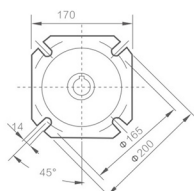
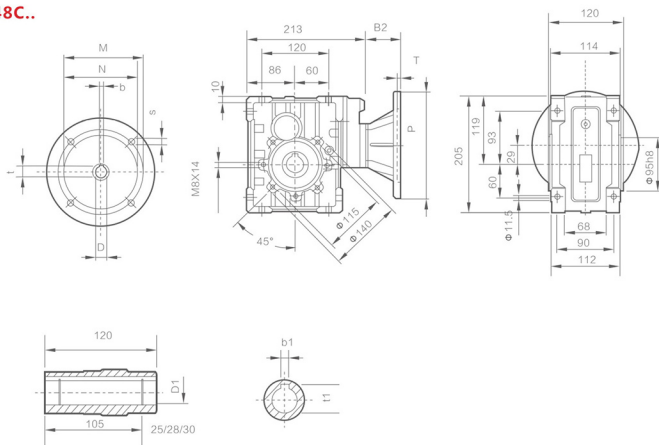

FA

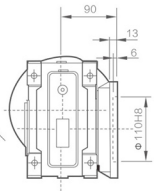
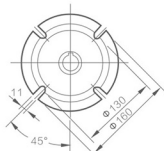
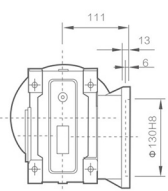

FB

IEC	DE8	b	t	P	M	N	S	T	L	D1 _{h8}	b1	t1
63B5	11	4	12.8	140	115	95	9	4	179	28	8	31.3
71B5	14	5	16.3	160	130	110	9	4	186	30*	8*	33.3*
80B5	19	6	21.8	200	165	130	11	4	206	35*	10*	38.3*
80B14	19	6	21.8	120	100	80	7	4	206	*非标产品，订单时请说明 *Only on request		
90B5	24	8	27.3	200	165	130	11	4	206	重量 (不包括马达) ≈10.8kg		
90B14	24	8	27.3	140	115	95	9	4	206	Weight without motor ≈10.8kg		

TKM..(IEC)外形尺寸图表 OUTLINE DIMENSION SHEET

TKM58B..

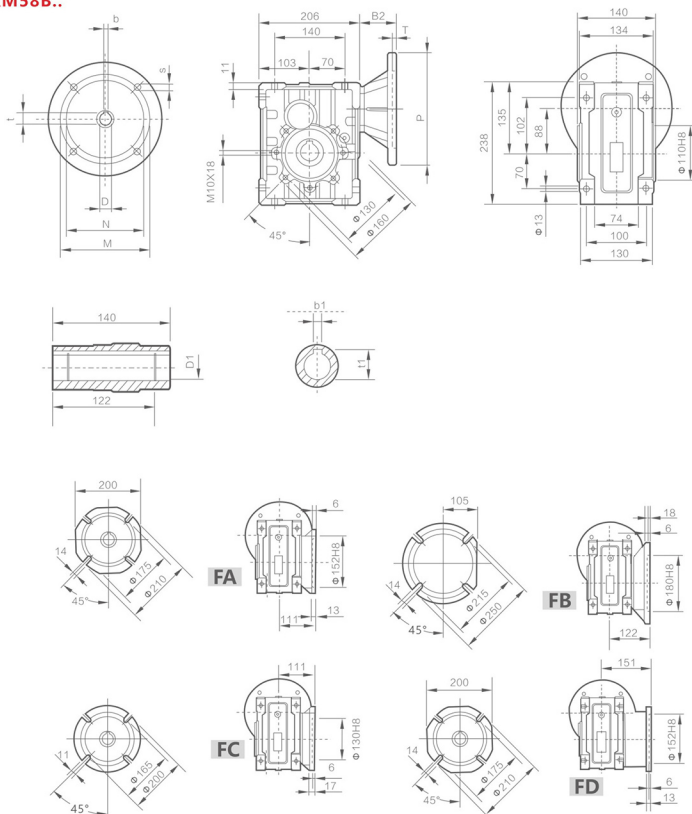

IEC	DE8	b	t	P	M	N	S	T	L	D1 _{IE}	b1	t1
71B5	14	5	16.3	160	130	110	9	4	162	33	10	38.3
80B5	19	6	21.8	200	165	130	11	4	182	38*	10*	41.3*
80B14	19	6	21.8	120	100	80	7	4	182	40*	10*	43.3*
90B5	24	8	27.3	200	165	130	11	4	182	*非标产品, 订单时请说明		
90B14	24	8	27.3	140	115	95	9	4	182	*Only on request		
100/112B5	28	8	31.3	250	215	180	13.5	4.5	192	重量 (不包括马达)		
100/112B14	28	8	31.3	160	130	110	9	4.5	192	=13.3kg		
										Weight without motor		
										=13.3kg		

TKM..(IEC)外形尺寸图表 OUTLINE DIMENSION SHEET

TKM58C..

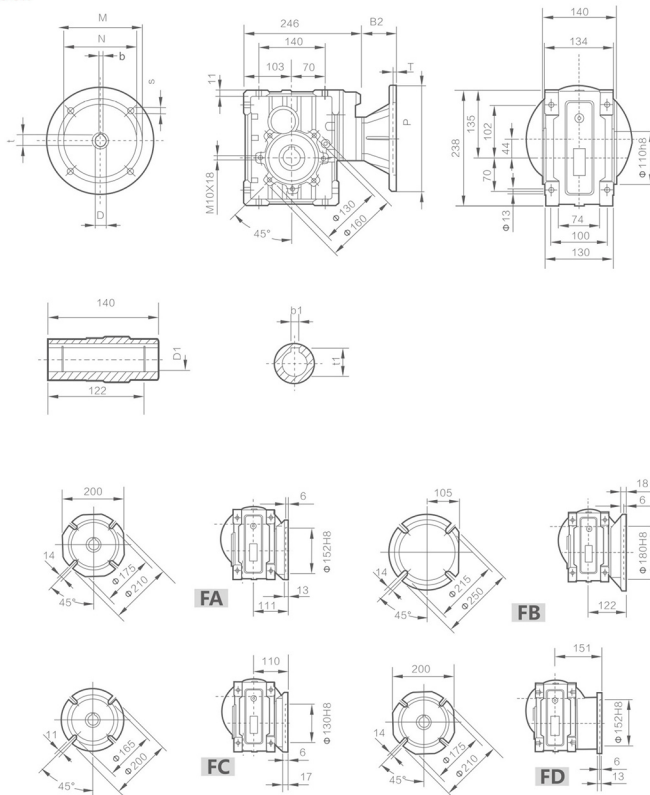

IEC	DE8	b	t	P	M	N	S	T	L	D1 _{h8}	b1	t1
63B5	11	4	12.8	140	115	95	9	4	195	35	10	38.3
71B5	14	5	16.3	160	130	110	9	4	202	38*	10*	41.3*
80B5	19	6	21.8	200	165	130	11	4	222	40*	10*	43.3*
80B14	19	6	21.8	120	100	80	7	4	222	*非标产品, 订单时请说明 *Only on request 重量 (不包括马达) ≈14.8kg Weight without motor ≈14.8kg		
90B5	24	8	27.3	200	165	130	11	2	222			
90B14	24	8	27.3	140	115	95	9	4	222			

TKM.. / MV外形尺寸图表 OUTLINE DIMENSION SHEET

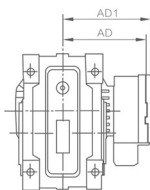
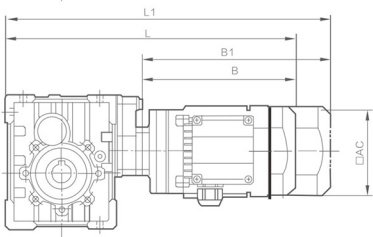
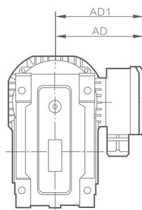
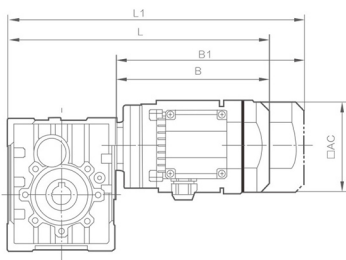

TYPE	MV..	L	L1	B	B1	AC	AD	Ad1
TKM28B	MV63..	328	376	207	255	118	110	115
	MV71..	343	393	222	272	134	122	127
	MV80..	386	440	265	319	142	129	134
	MV90..	426	496	305	375	158	137	142
TKM38B	MV63..	351	399	207	255	118	110	115
	MV71..	366	416	222	272	134	122	127
	MV80..	409	463	265	319	142	129	134
	MV90..	449	519	305	375	158	137	142
TKM48B	MV63..	384	432	211	259	118	110	115
	MV71..	399	449	226	276	134	122	127
	MV80..	442	496	269	323	142	129	134
	MV90..	482	543	309	370	158	137	142
	MV 100M..	498	568	325	395	182	165	165
	MV 100L..	528	598	355	425	182	165	165
MV 112..	546	626	373	453	206	178	178	
TKM58B	MV63..	417	465	211	259	118	110	115
	MV71..	432	482	226	276	134	122	127
	MV80..	475	529	269	323	142	129	134
	MV90..	515	576	309	370	158	137	142
	MV 100M..	531	601	325	395	182	165	165
	MV 100L..	561	631	355	425	182	165	165
MV 112..	579	659	373	453	206	178	178	

TYPE	MV..	L	L1	B	B1	AC	AD	Ad1
TKM28C	MV63..	362	410	207	255	118	110	115
	MV71..	377	427	222	272	134	122	127
TKM38C	MV63..	385	433	207	255	118	110	115
	MV71..	400	450	222	272	134	122	127
	MV80..	443	497	265	319	142	129	134
TKM48C	MV63..	424	472	211	259	118	110	115
	MV71..	439	489	226	276	134	112	127
	MV80..	482	536	269	323	142	129	134
	MV90..	522	583	309	370	158	137	142
TKM58C	MV63..	457	505	211	259	118	110	115
	MV71..	472	522	226	276	134	122	127
	MV80..	515	569	269	323	142	129	134
	MV90..	555	616	309	370	158	137	142

TKM.. / NEMA外形尺寸图表 OUTLINE DIMENSION SHEET

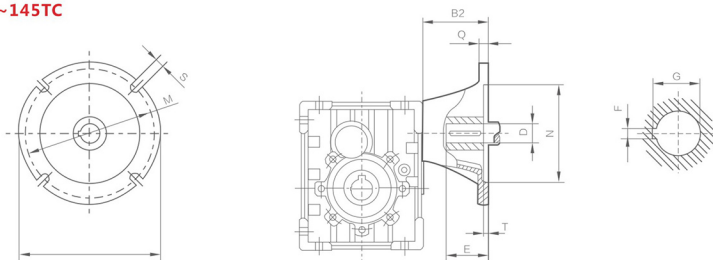
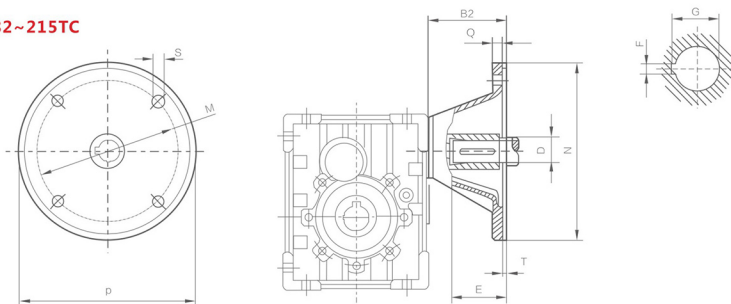
56C~145TC

182~215TC

TYPE	NEMA FLANGE	B ₂	D	E	F	G	M	N	P	Q	S	T
TK M28	56C	2.953	0.625	2.06	0.188	0.713	5.875	4.50	6.50	0.433	0.413	0.177
TKM38	56C	2.953	0.625	2.06	0.188	0.713	5.875	4.50	6.50	0.433	0.413	0.177
	143TC 145TC	2.953	0.875	2.12	0.188	0.963	5.875	4.50	6.50	0.433	0.413	0.177
TKM48	56C	3.228	0.625	2.06	0.188	0.713	5.875	4.50	6.50	0.433	0.413	0.177
	143TC 145TC	3.228	0.875	2.12	0.188	0.963	5.875	4.50	6.50	0.433	0.413	0.177
TKM58	182TC 184TC	3.937	1.125	2.62	0.250	1.240	7.250	8.50	9.00	0.472	0.551	0.197

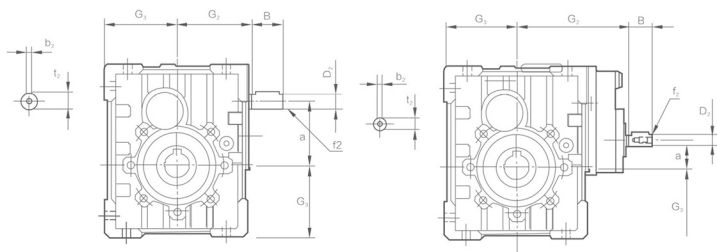
TKM...HS外形尺寸图表OUTLINE DIMENSION SHEET



TYPE	B	$D_{2.5}$	G_2	G_3	a	b_2	f_2	t_2
TKM28B	23	11	65	60	57	4	-	12.5
TKM28C	23	11	100	60	21.5	4	-	12.5
TKM38B	30	14	76	72	64.5	5	m6	16
TKM38C	23	11	111	72	29	4	-	12.5
TKM48B	40	16	91	86	74.5	5	m6	18
TKM48C	30	14	132	86	30.5	5	m6	16
TKM58B	40	19	107	103	88	6	m6	21.5
TKM58C	30	14	148	103	44	5	m6	16

TKM...HS附件尺寸图表OUTLINE DIMENSION SHEET

输出轴/Output Shafts

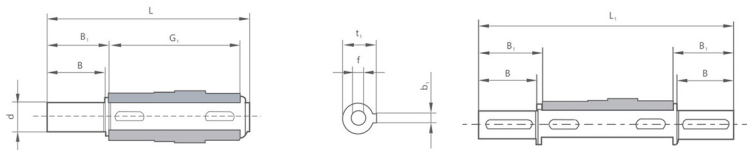

TYPE	d_{e6}	B	B_1	G_1	L	L_1	f	b_1	t_1
TKM28	25	50	53.5	92	153	199	M10X22	8	28
TKM38	25	50	53.5	112	173	219	M10X22	8	28
TKM48	28	60	63.5	120	192	247	M10X22	8	31
TKM58	35	80	84.5	140	234	309	M12X28	10	38

* 非标产品，订单时请说明
* Only onrequest

TKM..扭力臂/Torque Arm

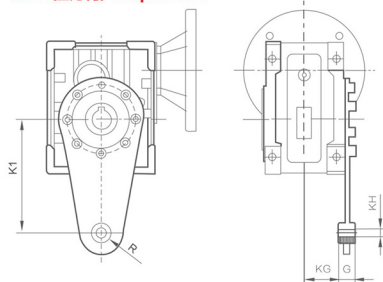

TYPE	K1	G	KG	KH	R
TKM28	100	14	38.5	10	18
TKM38	150	14	49	10	18
TKM48	200	25	47.5	20	30
TKM58	200	25	57.5	20	30

TKM..防尘盖/Cover

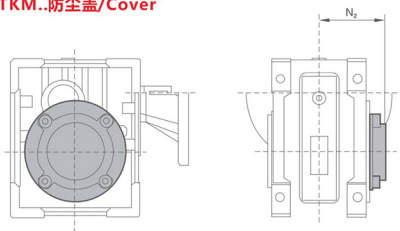

TYPE	N2
TKM28	63
TKM38	73
TKM48	79
TKM58	94

安装方位图/INSTALLATION POSITIONS DIAGRAM

输出法兰位置/Position diagram for output flange

FA1,FB1,FC1,FD1,FE1

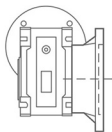

FA2,FB2,FC2,FD2,FE2



如没有特殊要求，一般按出厂的标准位置如图F..1方式和B3位置提供

Unless specified otherwise, the gear units is supplied with the flange in pos .F. .1 referred to position B3.

单向输出轴位置/Position diagram for single output shaft

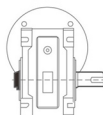

SS1

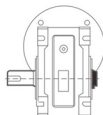

SS2



TKM..安装方式/Mounting positions

符号 Symbol	含义 meaning
	排气阀 Breather valve
	油位塞 Oil level plug
	放油塞 Oil drain plug

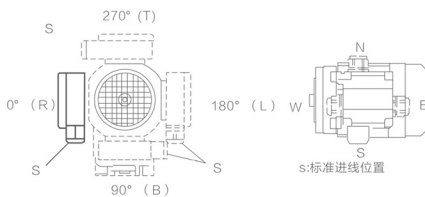

B3

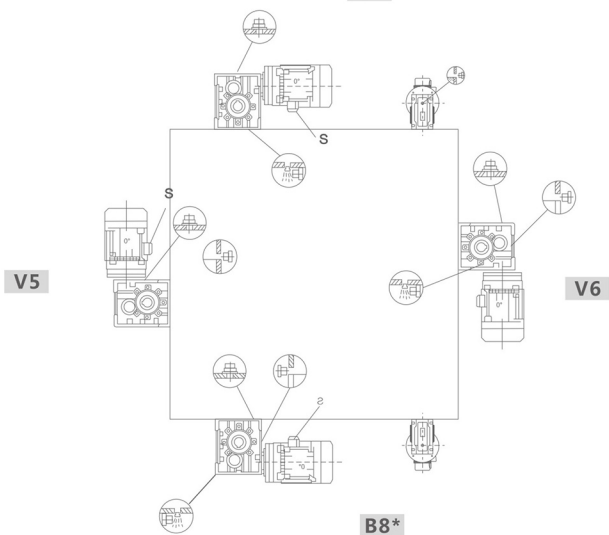

B6*

扭力臂/Torque Arm

B7*

表示在此安装方式，不能仅凭油位塞加注润滑油，油位需高出油位塞，加注量按表内所示。

It means the lubricant can't be added according to the oil level line plug, but also higher the plug the fill quantity as shown in the table

旋转方向/Direction of rotation



TKM..B



TKM..C

减速机在使用时,电机可正反旋转输入使用;推荐使用左图所示输入轴旋转方向为准双曲面齿轮最佳啮合方向。

The motor can be run either CW or CCW while using with gearbox,theleft chart is recommended

Note recommendations

To install the gear units it is necessary to note the following recommendations:

- ✓ Check the correct direction of rotation of the gear units output shaft before fitting the unit to the machine.
- ✓ Before mount with the prime mover and device,please check the reducer's every axial diameter, aperture, key and key slot, to be sure their dimensions are not deviation,and avoid assembling too tight or too loose,unless it wi1l influence the reducer's performance.
- ✓ The mountig on the machine must be stable to avoid anyvibration
- ✓ Whenver possible,protect the gear units against solar radiation and bad weather.
- ✓ In the case of particularly lengthy periods of storage (4-6 months) ,if the oil seal is not immersed in the lubricant inside the unit, it is recommended to change it since the rubber could stick to the shaft or may even hav lost the elasticity it needs to function properly
- ✓ Painting must definitely not go over rubber parts and the holes on the breather plugs,if any.
- ✓ When connect with hollow or solid shaft, please grease the joint to avoid lock or oxidation.
- ✓ Check the correct level of the lubricant through the indicator, if there is one.
- ✓ Starting must take place gradually, without immediately applying the maximum load.
- ✓ Supporting unit is required when using various of reducer matched with motor directly and the weight of motor is a little bigger than common.
- ✓ Ensure the motor cools correctly by assu ring good passage of air from the fan side.
- ✓ In the case of ambient temperatures<-5°C or>+40°C call the Technical Service.

安装/INTALLATION

注意事项

安装减速机时要注意以下一些事项:

- ✓ 减速机与机械设备装配之前,要检查减速机输出轴的旋转方向是否正确;
- ✓ 减速机与原动机、设备装配之前,应检查各轴径、孔径、键和键槽的偏差尺寸,避免装配过紧、过松影响减速器性能;
- ✓ 减速机必须牢固地安装在机械设备上,避免有松动或振动;
- ✓ 尽可能地避免减速机暴露在烈日阳光和恶劣环境中;
- ✓ 如果减速机存放时间长达4-6个月,应检查油封是否浸润在润滑油中,可能油封唇口会粘在轴上,甚至失去了弹性,由于适当的弹性是油封必须的工作条件,所以推荐更换油封;
- ✓ 所有橡胶件和透气孔不能沾有油污;
- ✓ 与减速器的空心轴或实心轴配合连接时,应在轴上配合部分涂上润滑油,以免卡死或氧化;
- ✓ 使用时必须检查油位(如油位镜孔或打开油塞,小型号是没有的);
- ✓ 使用新减速机时,不能满负载启动,应该逐步增大负载;
- ✓ 使用各类电机直联型减速机时,若电机重量偏大,应设支撑装置;
- ✓ 确保电机风扇附近有良好的通风环境,以免影响散热效果;
- ✓ 减速器的标准工作环境温度是-5℃至40℃,如果不在这个范围时,请与我们技术服务人员联系。

使用限制

这本样本给出的参数基本上是按B3安装方位来编的，即第一级没有完全浸入在油中。对于其他安装方位和输入转速，请参考下面表格中的相应参数。当遇到下列应用情况时，如有必要请与我们技术服务人员联系：

- ☑ 在原有上提高转速时；
- ☑ 应用在惯性特别大的设备上时；
- ☑ 当减速器出现故障有可能会对操作者造成危害时：
 - ☑ 应用在减速器过度疲劳状态时；
 - ☑ 工作环境温度低于-5℃或高于40℃时；
 - ☑ 在化学腐蚀环境中使用时；
 - ☑ 在盐性环境中使用时；
 - ☑ 在辐射性高的环境中使用时；
 - ☑ 在环境气压不在正常大气压力下使用时；
- ☑ 安装方位在这样本中没有提到时。

避免把减速器部分或整台浸入水里或其它液体中。

减速器承受的最大负载扭矩不能超过两倍于性能参数表中规定的正常扭矩(当使用系数 $f_s=1$ 时)；这里最大负载扭矩是指能承受瞬间短暂的过载，它出现在过载启动、刹车、振动或其它动态操作环境中。

Critical applications

The performance given in the catalogue correspond to mounting position B3 or similar, when the first stage is not entirely immersed in oil. For other mounting positions and/or particular input speeds, refer to the tables that highlight different critical situations for each size of gear units. It is also necessary to take due consideration of and carefully assess the following applications by calling our Technical Service:





- ☑ As a speed increasing.
- ☑ Applications with especially high inertia
- ☑ Use in services that could be hazardous for people if the gear units fails.
- ☑ Applications with high dynamic strain on the case of the gear units.
- ☑ In places with T° under -5°C or over 40°C .
- ☑ Use in chemically aggressive environments.
- ☑ Use in a salty environment.
- ☑ Use in radioactive environments.
- ☑ Use in environments pressures other than atmospheric pressure.
- ☑ Mounting positions not envisaged in the catalogue.

Avoid applications where even partial immersion of the gear units is required.

The maximum torque that the gear units can support must not exceed two times the nominal torque ($f_s=1$) stated in the performance tables. Intended for momentary overloads due to starting at full load, braking, shocks or other causes, particularly those that are dynamic.

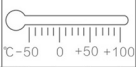
润滑油/LUBRICATION

润滑油型号/Types of lubrication

	 °C -50 0 +50 +100	 ISO	 SHELL	 Mobil mobil	 bp BP	润滑油类型 lubrication type
TKM..	标准 Standard -10 +40	VG220	Shell Omala S2 G220	Mobilgear 600XP 220	BP Energol GR-XP 220	矿物油 Mineral oil
	-20 +25	VG150 VG100	Shell Omala S2 G100	Mobilgear 600 XP 100	BP Energol GR-XP 100	
	-30 +10	VG68-46 VG 32	Shell Tellus S2 V32	Mobil Excel™ 32		
	-40 +20	VG 22 VG 15	Shell Tellus S2 V15	Mobil Excel™ 15	BP Energol HLP-HM 15	合成油 Synthetic oil
	-40 +30	VG220	Shell Omala S4 GX220	Mobil SHC 630		
	-40 +40	VG150	Shell Omala S4 GX150	Mobil SHC 629		
	-40 +10	VG32	Shell Omala S4 ATF HDX	Mobil SHC 624		

润滑油加注量

规定的加注量为参考值。精确值的变化与级数和传动比有关。请您在加注润滑油时一定要注意油位螺栓所指示的精确油量。后期调整安装方式时，您必须根据改变后的安装方式相应调整加注润滑油。下表中列出了不同安装方式(B3.B6, B7.....)的减法器相应的标准参考润滑油注入量值。

Lubricant fill quantity

The specified fill quantities are recommended values. The precise values vary depending on the number of stages and gear ratio. When filling, it is essential to check the oil level plug since it indicates the precise oil capacity. The following tables show guide values for lubricant fill quantities in relation to the mounting position (B3, B6, B7....)

TKM..润滑油加质量/Lubricant fill quantity

减法器型号 Gear units	加注量 Fill quantity in liters					单位: 升 (L)	
	B3	B6	B7	B8	V5	V6	
TKM28B	0.22	0.2*	0.13*	0.15	0.25	0.14	
TKM28C #	0.07	0.04	0.04	0.05	0.08	0.09	
TKM38B	0.42	0.35*	0.24*	0.22	0.46	0.25	
TKM38C #	0.07	0.04	0.04	0.05	0.08	0.09	
TKM48B	0.70	0.58*	0.42*	0.42	0.75	0.45	
TKM48C #	0.13	0.09	0.09	0.09	0.15	0.17	
TKM58B	1.21	0.95*	0.72*	0.67	1.30	0.74	
TKM58C #	0.13	0.09	0.09	0.09	0.15	0.17	

维护 MAINTAIN

维护

- ☑ 对于齿轮箱，首次换油必须在工作大约300小时（齿轮磨合期）后进行，在换油时应使用合适的清洗剂小心心的冲洗齿轮箱，不得将矿物油和合成油混合
- ☑ 每3000工作小时，最低程度半年，应检测油位及油封，油封密封不严引起滴漏的常规检测，若是IEC输入的减速器，则检测检查弹性体，必要时进行更换。
- ☑ 根据不同的工作条件(见下图)而定，最长每三年检测一次，更换矿物油;更换轴承润滑油脂。
- ☑ 根据不同的工作条件而定，更换输出轴上的油封。
- ☑ 产品出现故障时，不要拆卸部件，与本公司售后服务部门联系(需提供减速器规格、出厂日期、编号、已使用时间、主机名称、主机生产单位和故障类型)后，再采取合理的措施。

MAINTENANCE

- ☑ For gear units, first oil change should be after about 300 hours (run-in period). The right lotion is required to clean the gear units with care. Never mix the synthetic oil and mineral oil together.
- ☑ Every 3000 working time, at least every 6 months, you have to check the oil and oil level, the seals visually for leakage. For IEC input gear units the elastomer should be tested or replaced if necessary.
- ☑ Depending on the operating conditions (seechart below), every 3 years at the latest for inspection is needed. Then change the mineral oil andreplace the bearing grease.
- ☑ Depending on the operating conditions,change the oil seals on output shaft
- ☑ Once the malfunctions appear, stop disassembling the parts, and firstly please contact the customer service (the information about specification, delivery date, series number, time used, name of machine, machine manufacturer, malfunction problems is required), then take the reasonable measures.

存放 / 定货须知 STORAGE/NOTICE FOR ORDER

适用于正常环境条件下标准减速器的更换时间间隔

Oil change intervals for standard gear unyts under normal environmental conditions

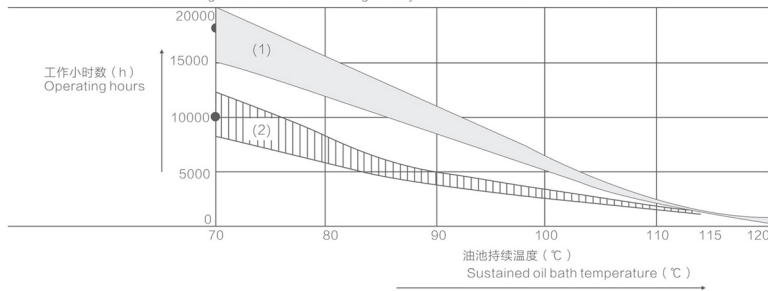

每种机油类型的平均值为70° C
Average value per oil type at 70°C

合成油 Synthetic oil
矿物油 Mineral oil

存放

- ☑ 有顶棚，防雨雪，无振动。
- ☑ 在设备和地面之间垫放木块或其他材料。
- ☑ 开箱后暂不使用的齿轮减速器在其加工表面涂上防锈油，并应及时放回包装箱内。
- ☑ 在定期检查的情况下，两年以及更长时间。在进行检查时，应检查清洁度和机械损伤，检查防锈层是否完好。

STORAGE

- ☑ Under roof, protected against rain and snow, no shock loads.
- ☑ Underlay the block and other material between the ground and equipment.
- ☑ The opened but not used gear units should be added with the anticorrosive oil on its surface, and then return to the packing containers timely.
- ☑ Two years or more given regular inspections. Check for cleanliness and mechanical damage as part of the inspection. Check corrosion protection.

订货须知

减速器定单请向我们提供以下信息:

- ☑ 减速器型号标记(减速器类型、速比、功率和安装方式)。
- ☑ 减速器表面喷涂颜色，一般按银白色提供。
- ☑ 订购数量。
- ☑ 其他特殊要求。
- ☑ 单位名称，联系人，联系电话。

NOTICE FOR ORDER

Please offer the following information when place the orders:

- ☑ the model mark of the gear units(type, ratio, power and mounting position).
- ☑ generally the gear units paint in silver.
- ☑ quantity ordered.
- ☑ other special requirements.
- ☑ company, contact and telephone.

减速器运转故障/GEAR UNIT MALFUNCTIONS

故障	可能的原因	解决办法
异常、均匀的运转噪声。	A.滚动/碾压噪声：轴承损坏。 B.冲击型噪声：齿轮啮合不均匀	A.检测润滑油，更换轴承 B.请向客户服务部咨询。
异常、不均匀的运转噪声。	机油中有异物	检测润滑油 停止运转传动装置，向客户服务部咨询
机油泄露 · 在减速器盖上 · 在电机凸缘上。 · 在电机轴承封圈上 · 在减速器凸缘上。 · 在输出端轴密封圈上	A.减速器底座上的橡胶密封发生渗漏 B.密封圈损坏 C.减速器没有排气	A.拧紧各个外盖上的螺钉并且观察减速器。 如果机油继续泄露，请向客户服务部咨询。 B.请向客户服务部咨询 C.给减速器排气（参见“安装方式”）
机油从排气阀旁渗出	A.机油太多 B.传动装置安装方式错误 C.频繁冷启动（机油起泡沫）和/或者较高的油位	A.修正油量（参见“润滑油”） B.正确安装排气阀并且修正油位（参见“安装方式”）
尽管电机在运转或者传动轴已经被驱动，但是传动轴不转动。	减速器中的轴轮联接断裂	将减速器或减速机送修

1) 在磨合运转阶段（24小时的运转时间内），轴密封圈有可能出现短期内的漏油/油脂的现象。

Problem	Possible Cause	Remedy
Unusual, regular running noise	A. Meshing/grinding noise: Bearing damage. B. Knocking noise: Irregularity in the gearing	A. Check the oil · change bearings B. Contact customer service
Unusual, irregular running noise	Foreign bodies in the oil	· Check the oil · Stop the drive, contact customer service
Oil leaking 1) · From the gear cover plate · From the motor flange · From the motor oil seal · From the gear unit flange · From the output end oil sea	A. Rubber seal on the gear cover plate leaking B. Seal defective C. Gear unit not vented	A. Tighten the bolts on the gear cover plate and observe the gear unit. Oil still leaking: Contact customer service B. Contact customer service C. Vent the gear unit (see "Mounting Positions")
Oil leaking from breaking valve	A. Too much oil B. Drive operated in incorrect mounting position C. Frequent cold starts (oil foams) and/or high oil level	A. Correct the oil level (see Sec. "Inspection and Maintenance") B. Mount the breather valve correctly (see Sec. "Mounting Positions") and correct the oil level (see "Lubricants")
Output shaft does not turn although the motor is running or the input shaft is rotated	Connection between shaft and hub in gear unit interrupted	Send in the gear unit/gearmotor for repair

1) Short-term oil/grease leakage at the oil seal is possible in the run-in phase (24 hours running time).

减速器负载特征表/CHARGE CHARACTERISTIC CHART (参考件)/(FOR REFERENCE)

风机类 AIR BLOWERS		卷扬机齿轮传动装置 Hoist gear assembly	A
风机 (轴向和径向) Air blower(axial or radial)	A	吊杆起落齿轮传动装置 Derrick gear assembly	B
冷却塔风扇 Fan of cooling tower	B	转向齿轮传动装置 Steering gear assembly	B
引风机 Induced draught fan	B	行走齿轮传动装置 Moving gear assembly	C
螺旋活塞式风机 Rotary piston type fan	B	挖泥机类 LAND DREDGER	
涡轮式风机 Turbo-fan	A	筒式输送机 Drum-type conveyor	C
建筑机械类 CONSTRUCTION MACHINERY		筒式转动机 Drum-type rotation wheel	C
混凝土搅拌机 Concrete mixer	B	挖泥头 Dredger head	C
卷扬机 Hoist	B	机动绞车 Powered crab	B
路面建筑机械 Road building machinery	B	泵 Pump	B
钻孔机 Boring mill	B	泵转向齿轮传动装置 Pump turning gear assembly	B
化工机械类 CHEMICAL MACHINERY		行走齿轮传动装置(履带) Moving gear assembly (apron wheel)	C
搅拌机 (液体) Mixer (liquid)	A	行走齿轮传动装置 (铁轨) Moving gear assembly (track)	B
搅拌机 (半液体) Mixer (half liquid)	B	食品工业机械类 FOODSTUFF PROCESSING MACHINERY	
离心机 (重型) Centrifuge (heavy)	B	灌注及装箱机器 Placer or box filler	A
离心机 (轻型) Centrifuge(light)	A	甘蔗压榨机 Cane crusher	A
冷却滚筒** Cooling rolling drum	B	甘蔗切断机** Cane cutter	B
干燥滚筒** Dry rolling drum	B	甘蔗粉碎机** Cane crasher	C
搅拌机 Mixer	B	搅拌机 Mixer	B
压缩机械类 COMPRESSOR		酱状物吊筒 Paste bucket	B
活塞式压缩机 Piston type compressor	C	包装机 Packager	A
涡轮式压缩机 Turbo-compressor	B	糖甜菜切断机 Beet slicer	B
传送运输机类 TRANSMISSION FREIGHTER		糖和甜菜清洗机 Beet washing machine	B
平板输送机 Pan conveyor	B	发动机及转换器类 MOTOR AND CONVERSION EQUIPMENTS	
平衡块升降机 Balance lifter	B	频率转换器 Frequency converter	C
槽式输送机 Trough conveyor	B	发动机 Motor	C
带式输送机 (大件) Ribbon conveyor (large piece)	C	焊接发动机 Welding motor	C
带式输送机 (碎料) Ribbon conveyor (small piece)	B	洗衣机类 WASHING MACHINE	
筒式面粉输送机 Drum-type flour conveyor	A	滚筒 Rolling drum	B
链式输送机 Chain conveyor	B	洗衣机 Washing machine	B
环式输送机 Ring type conveyor	B	金属滚轧机类 METAL ROLLER MACHINE	
货物升降机 Lifter	B	钢坯剪断机** Steel cutter	C
卷扬机 Hoist	B	链式输送机** Chain conveyor	B
连杆式输送机 Crank-connecting conveyor	B	冷轧机** Cold mill	C
载入升降机 Lifter	B	连铸成套设备 Continuous casting equipments	B
螺旋式输送机 Worm conveyor	B	冷床** Cold bed	B
钢带式输送机 Steel-band conveyor	B	剪料机头** Cropper	C
链式槽型输送机 Chain reed-type conveyor	B	交叉转弯输送机** Cross steering transmitter	B
绞车运输机 Crab freighter	B	除锈机** Deruster	C
起重机械类 HOIST		重型和中型板轧机** Heavy and medium steel mill	C
转臂式起重传动齿轮装置 Bracket swing gear assembly	B	棒坯切轧机** Bar mill	C

减速器负载特征表/CHARGE CHARACTERISTIC CHART (参考件)/(FOR REFERENCE)

捧还转运机类 BAR TRANSMISSION EQUIPMENTS		B	泵类 PUMPS	
捧还推料机 Bar pusher		B	离心泵 (稀液体) Centrifugal pump (thin liquid)	A
推床 Push bed		B	离心泵 (半液体) Centrifugal pump (half liquid)	B
剪板机** Shears		C	活塞泵 Displacement pump	C
板材摆升降台** Lumber elevator platform		B	柱塞泵 Plunger pump	C
轧辊调整装置 ROLL ADJUSTING EQUIPMENTS		B	压力泵 Force pump	C
辊式矫直机 Roller leveling machine		C	塑料机械类 PLASTIC EQUIPMENTS	
轧钢机辊道 (重型)** Mill rolling way (heavy)		B	压光机** Glazing press	B
轧钢机辊道 (轻型)** Mill rolling way (light)		B	挤压机** Ejecting press	B
薄板轧机** Sheet rolling mill		C	螺旋压出机** Spiral extruding machine	B
修整剪切机** Trimming shears		B	混合机** Mixing machine	B
焊管机 Pipe welder		C	橡胶机械类 RUBBER EQUIPMENT	
焊管机 (带材和线材) Soldering machine(belt material and wire rod)		B	压光机** Glazing press	B
线材拉拔机 Wire drawbench		B	挤压机** Ejecting press	C
金属加工机床类 METAL PROCESSING MACHINE TOOLS			混合搅拌机** Mixing stir machine	B
动力轴 Power shaft		A	捏合机 Kneading machine	B
锻造机** Forging machine		C	滚压机** Roller machine	C
锻锤 Drop hammer		A	石料、瓷土料加工机械类 STONE PORCELAIN CLAY PROCESSING EQUIPMENTS	
机床及辅助装置 Machine tool and necessary		C	球磨机 Ball crusher	B
机床及主要传动装置 Machine tool and main driving equipment		B	挤压料破碎机** Ejecting press and breaker	C
金属刨床 Metal facing machine		C	破碎机 Breaker	C
板材矫直机床 Plate-leveling machine tool		C	压砖机 Brick press	C
冲床 Backing-out punch		C	锤料破碎机** Beating crusher	C
冲压机床 Press machine tool		B	转炉** Converter	C
剪床 Cutting machine		B	筒型磨机** Cylinder mill	C
薄板弯曲机床 Sheet bending machine tool		B	纺织机械类 TEXTILE MACHINERY	
石油工业机械类 PETROLEUM PROCESSING MACHINERY			送料机 Feeding machine	B
输油管油泵** Pump of oil pipe line		B	织布机 Loom machine	B
转子钻井设备 Rotary drilling equipment		C	印染机 Dyeing machine	B
制纸机类 PAPERING MACHINE			精制筒 Purified drum	B
压光机** Glazing press		C	威罗机 Welon machine	B
多层纸板机** Multilayer paper board machine		C	水处理设备类 WASTER TREATMENT EQUIPMENTS	
干燥滚筒** Drying cylinder		C	鼓风机** Air blast	B
上光滚筒** Glazing cylinder		C	螺杆泵 Screw pump	B
搅浆机** Masher		C	木料加工机床 WOOD PROCESSING MACHINE TOOL	
搅浆擦碎机** Mashing and breaking machine		C	剥皮机 Barker	C
吸水滚** Suction roll		C	刨床 Facing machine	B
潮纸滚压机** Wet paper roller machine		C	锯床 Saw bench	C
吸水滚压机木** Water absorbing roller machine		C	木材加工机床 Wood processing machine tool	A
威罗机 Welon machine		C		

注: A-均匀冲击负载; B-中等冲击负载; C-重冲击负载; **-用于24小时工作制。

Note:A-Uniform load;B-Moderate shock load;C-Heavy shock load;**-for 24hour system.

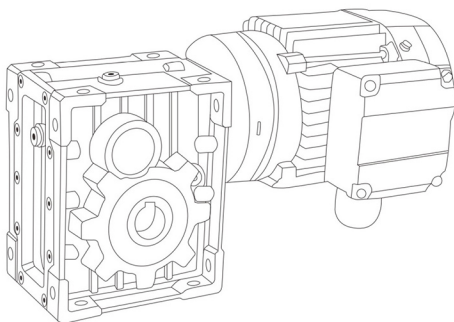

◆ 本公司产品因不断的改良与设计，此目录在未预告的情况下，有更改产品设计的可能，敬请谅解。
如有未尽详细之处，请与本公司营业处洽询。

温州库盛电机科技有限公司

Wenzhou Kusheng Motor Technology Co., LTD

地址：浙江省温州市乐清市北白象镇象西高新创业园千亿路1号
Add: Changdaotian Industrial Zone, Liushu, Wenzhou,
Zhejiang PR, China.

邮编：325604

电话(TEL)：86-577-62712822 62712255 62715811
62717798 62717799

传真(FAX)：86-577-62712811

E-mail: tim@tm.net.cn
<http://www.ksdj.com>



经销商：